

FOR WALLS



FOR FLOORS



FOR ROOFS

 **EcoTherm**[®]
Insulation

EcoTherm Eco-Cavity Full Fill Standard Details 90mm in a 100mm Cavity

Version 2 - August 2017



Contents

3	Introduction
6	E1 - Lintel with Perforated Steel Base Plate - Insulated (30mm overlap between frame and cavity)
7	E2 - Lintel without Base Plate - Insulated (30mm overlap between frame and cavity)
10	E3 - Sill (30mm overlap between frame and cavity)
12	E4 - Jamb (30mm overlap between frame and cavity)
14	E5 - Ground Floor (solid concrete - insulation below screed)
16	E5 - Ground Floor (beam and block - parallel)
18	E5 - Ground Floor (beam and block - perpendicular)
20	E6 - Intermediate Floor within a Dwelling (concrete)
22	E6 - Intermediate Floor within a Dwelling (timber)
24	E7 - Party Floor between Dwellings
26	E10 - Eaves (insulation at ceiling level)
28	E11 - Eaves (insulation at rafter level)
30	E12 - Gable (insulation at ceiling level)
32	E13 - Gable (insulation at rafter level)
34	E14 - Flat Roof
36	E15 - Flat Roof with Parapet
38	E16 - Corner (normal)
40	E17 - Corner (inverted)
42	E18 - Party wall between Dwellings (filled cavity)



A significant amount of the heat lost from a building is lost through the interactions between elements, from the junctions between walls and floors, from its corners, from the junctions between walls and roofs and around its windows and doors.

At these points of increased heat loss, localised reductions of internal surface temperatures can occur, leading to surface condensation and mould growth problems. To avoid these issues, good design detailing is important.

The details in this guidance have been developed with the aim of being buildable, achieving a good level of thermal performance and minimal risk.

Junctions & Building Compliance

The heat loss through a junction is referred to as a ψ -value (psi-value) and is measured in W/mK, a linear heat loss per metre of junction. This heat loss is additional to loss through the adjoining elements, which is taken account of in U-value calculations.

Whole building calculation methodologies (such as SAP in the UK for domestic purposes, or SBEM for non-domestic) are used to assess the operational CO₂ emissions of buildings; the heat loss from junctions are taken account of in these calculations alongside losses from walls, roofs, floors, openings and ventilation.

When specifying thermal bridging for domestic properties, there are various approaches that can be adopted:

- a.** where 'Approved Design Details' are followed, ψ -values from the approved column on Table K1 of SAP2012 can be used, or alternatively, ψ -values associated with the particular approved source detail can be taken;
- b.** bespoke ψ -values can be used, that have been calculated by a person with suitable expertise and experience in accordance with BRE IP 1/06 and BR 497 (Conventions for Calculating Linear Thermal Transmittance and Temperature Factors);

- c.** where an approved or modelled junction detail is unavailable, a ψ -value from the 'default' column of SAP2012, Table K1 can be used for a junction.

In each of these cases, the given ψ -values are used along with the length of each junction and a combination of a, b, and c. can be used; or

- d.** if none of the above applies, or is appropriate for what is being constructed, then a global default value for overall heat loss in the energy calculation can be taken, to account for thermal bridging (a value of 0.15 W/m²K is added to overall elemental losses, making it harder to achieve compliance). This approach is no longer considered appropriate for Scottish compliance (and may underestimate the overall losses).

The ψ -values in this document have all been calculated by Competent Thermal Modellers (who have successfully completed training and portfolios with ACD Certification Ltd and who are experienced in thermal modelling of junction heat losses).

ψ -values have been created for the major junctions involving Eco-Cavity Full Fill (90mm in a 100mm cavity), following the guidelines in BR 497.

Introduction

Critical Temperature Factors

To avoid surface condensation or mould growth occurring as a result of thermal bridges, reasonable provision should be made to demonstrate that details achieve a temperature factor that is no worse than the performance set out in BRE IP 1/06.

The temperature factor is a property of the construction, surface resistances and internal and external temperatures. This is used to assess the risk of surface condensation or mould growth. This parameter has been provided for all of the junction variants.

In all cases the calculated values for the modelled Eco-Cavity Full Fill details achieve acceptable temperature factors, being higher than the critical temperature factor for dwellings (fCRsi of 0.75) as given in BRE IP 1/06, which limits the risk of surface condensation or mould growth. For higher humidity condition buildings, such as swimming pools (fCRsi of 0.90), these may require alternative details and constructions.

Calculation Methodology

The thermal modelling of the Eco-Cavity Full Fill details was undertaken using two transient and steady state heat transfer software packages produced by Blocon (as appropriate for the detail). HEAT 2 was used for the two-dimensional details and HEAT 3 for the three-dimensional details.

The modelled U-values and underfloor temperatures for suspended and beam and block floors were determined using the STROMA U-value calculator.

Junctions were modelled using a 90mm

thickness of Eco-Cavity Full Fill in an overall 100mm cavity (with a 10mm residual cavity) and with a variety of internal leaf blockwork types; these included a standard lightweight blockwork at 0.15 W/mK, a version with medium dense blockwork (0.51 W/mK) and one with dense blockwork (1.13 W/mK).

How to Use these Details

The detail sheets in this document include a process sequence and also guidance on how to achieve a good level of air-tightness.

The ψ -values and temperature factors are provided for different bands of internal leaf blockwork conductivity. Where a different conductivity blockwork is used, performance can be inferred from the poorest closest blockwork modelled.

The ψ -values cited may be used in calculations of building heat loss, where the principles of construction and key element specifications have been followed.

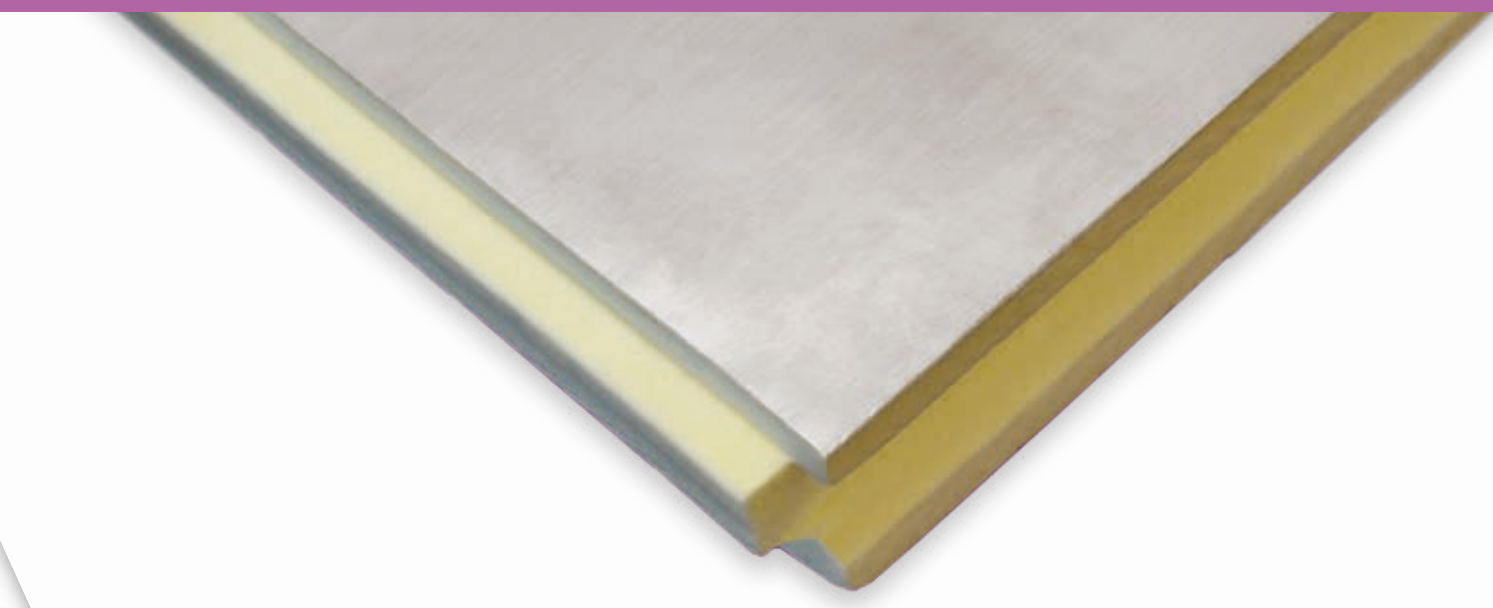

Limitations & Applicability of Modelling

The calculated ψ -values in this document can be considered to be valid to two significant figures where the internal finish is either plaster or plasterboard on dabs, with or without skim.

The ψ -values could also be reasonably used whenever the external leaf of the construction is constructed either from external brickwork, or stonework, or where the external leaf is rendered blockwork, with the external leaf being no less than 100mm in thickness.

For junctions around window and door openings, a 30mm overlap between the window frame and the cavity has been assumed. Where a full overlap between the frame and cavity, or a check reveal is used instead, the thermal performance of those constructions would be better, so the calculated value with a 30mm overlap can be considered a worst case value.

Calculated ψ -values can be used by energy assessors for buildings constructed in accordance with associated details for buildings constructed in England, Scotland, Wales and Northern Ireland.

Where proposed constructions significantly differ from the enclosed process sequences, or use alternative materials, these ψ -values and temperature factors should not be used.

These details represent typical detailing to achieve a good level of thermal performance, however the details included in this document may not be suitable for use in all circumstances. Where there is any uncertainty, Building Control Body (BCB) requirements and advice should always be sought and followed. All other site requirements and relevant building regulations must be taken into consideration when implementing the details.

This document refers to Eco-Cavity Full Fill in a 90mm thickness, when used in a 100mm cavity. For further guidance on other available thicknesses, please contact the EcoTherm Technical Department on: **Tel: 01268 597 212**
Email: technical@ecotherm.co.uk

E1 - Lintel with Perforated Steel Base Plate - Insulated

(30mm overlap between frame and cavity)

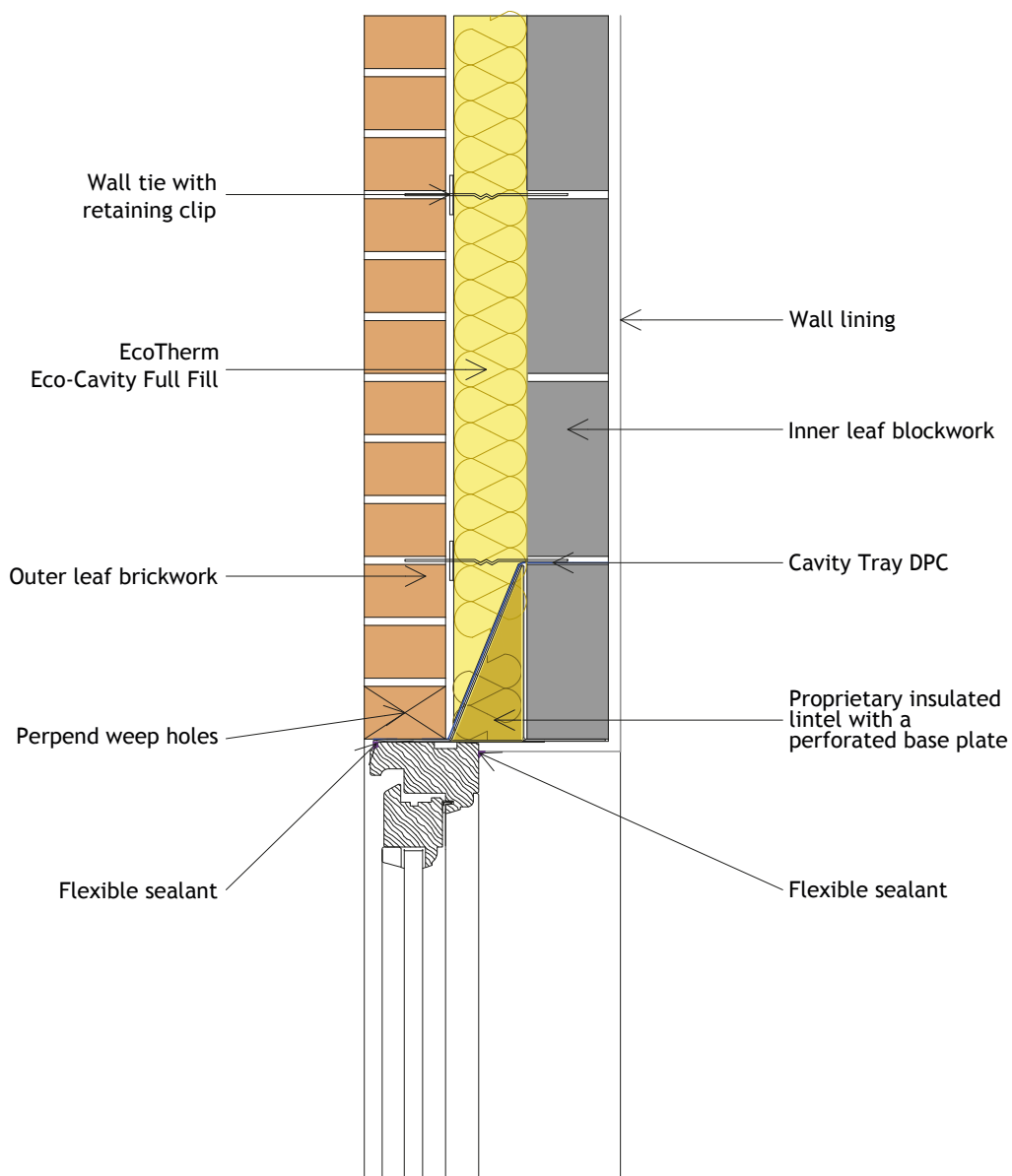

General Construction Specification:

Wall lining; inner leaf blockwork; Eco-Cavity Full Fill board;
10mm residual cavity; brickwork

U-value Range Covered:

Inner Block Density	U-value achieved
0.15 W/mK	0.18 W/m ² K
0.51 W/mK	0.19 W/m ² K
1.13 W/mK	0.20 W/m ² K

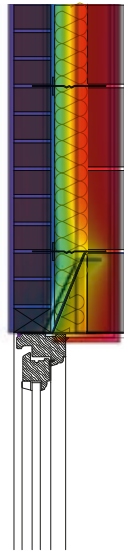

Thermal Performance Process Sequence:

- Ensure Eco-Cavity Full Fill board is in contact with lintel
- Ensure Eco-Cavity Full Fill board and cavity tray / proprietary insulated lintel are lightly butted
- Ensure there are no gaps in the Eco-Cavity Full Fill board
- Ensure window / door frame overlaps the insulated lintel by no less than 30mm
- Ensure the Eco-Cavity Full Fill board is firmly held against the inner leaf of blockwork
- Ensure cavity and wall ties are kept clean of mortar or other debris during construction
- Tongue & grooved (T&G) edges to be tightly interlocked
- T&G edges to be trimmed at interfaces to form a tight butt edge
- For fully overlapped / checked reveals ensure the window / door frame overlaps the insulated lintel fully / by no less than 80mm. All Psi values will be at least as good as the normal overlap

Air Barrier Process Sequence:

- Seal the joint between the window frame and the internal linings
- Apply flexible sealant to all interfaces between the internal air barrier and the window / door frame
- Seal all penetrations through the air barrier using a flexible sealant

Results:

Description	Internal Blockwork Conductivity (W/mK)		
	0.15	0.51	1.13
Linear Thermal Transmittance ψ (W/mK)	0.255	0.293	0.314
Temperature Factor (f)	0.950	0.932	0.928

E2- Lintel without Base Plate-Insulated

(30mm overlap between frame and cavity)

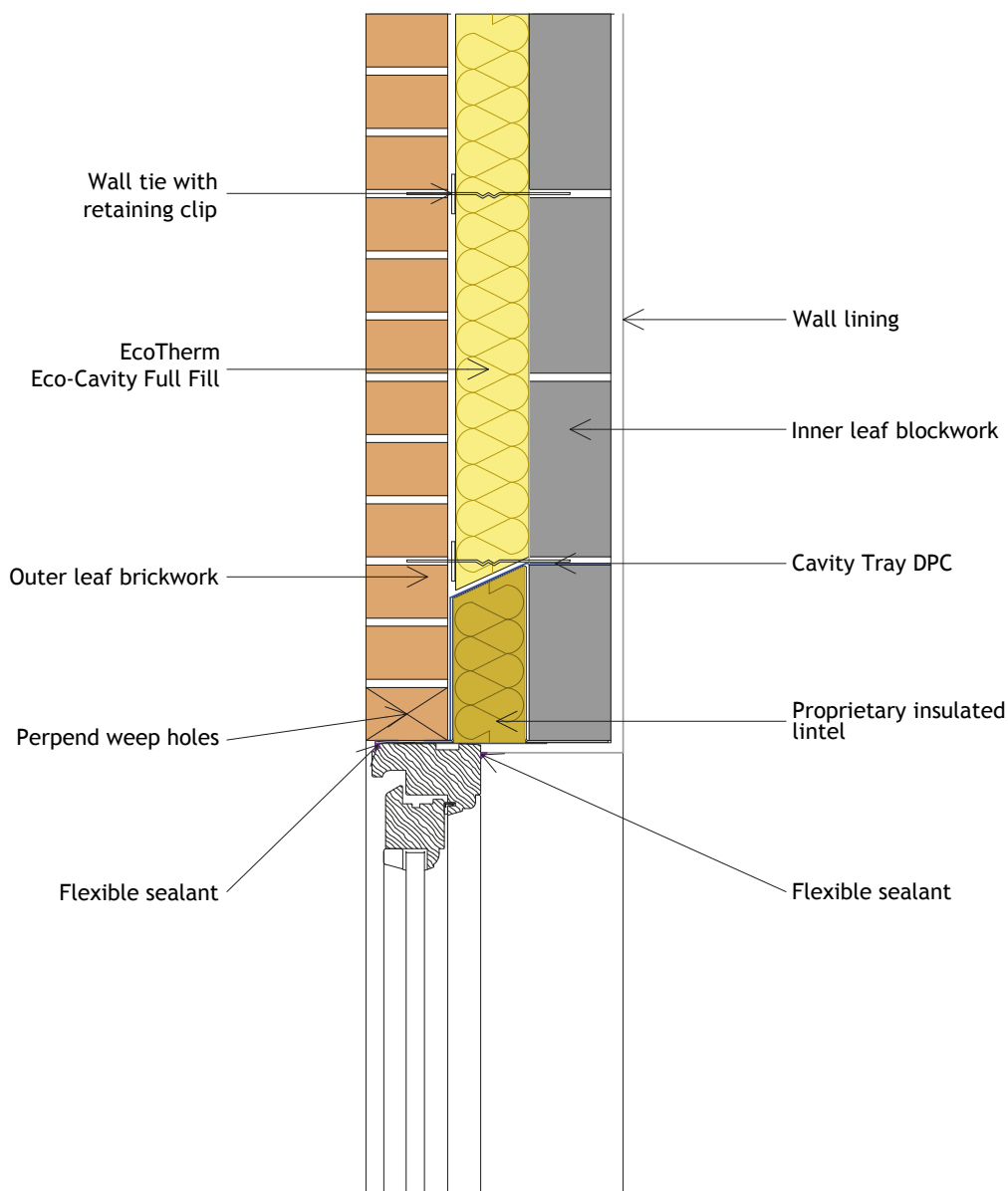

General Construction Specification:

Wall lining; inner leaf blockwork; Eco-Cavity Full Fill board; 10mm residual cavity; brickwork

U-value Range Covered:

Inner Block Density	U-value achieved
0.15 W/mK	0.18 W/m ² K
0.51 W/mK	0.19 W/m ² K
1.13 W/mK	0.20 W/m ² K

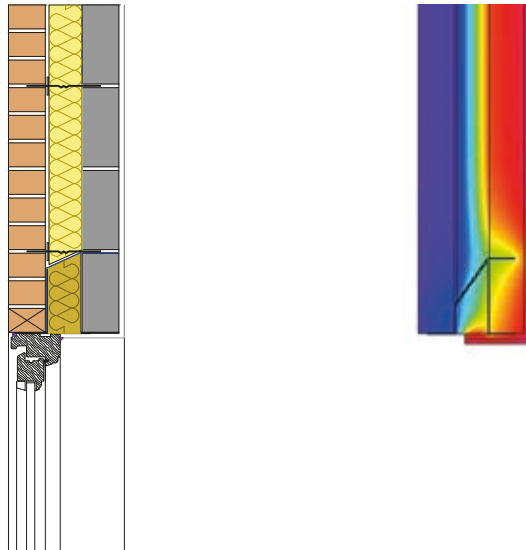

Thermal Performance Process Sequence:

- Ensure Eco-Cavity Full Fill board is in contact with lintel
- Ensure Eco-Cavity Full Fill board and cavity tray / proprietary insulated lintel are lightly butted
- Ensure there are no gaps in the Eco-Cavity Full Fill board
- Ensure window / door frame overlaps the insulated lintel by no less than 30mm
- Ensure the Eco-Cavity Full Fill board is firmly held against the inner leaf of blockwork
- Ensure cavity and wall ties are kept clean of mortar or other debris during construction
- T&G edges to be tightly interlocked
- T&G edges (tongue) to be trimmed at interfaces to form a tight butt edge
- For fully overlapped / checked reveals ensure the window / door frame overlaps the insulated lintel fully / by no less than 80mm. All Psi values will be at least as good as the normal overlap

Air Barrier Process Sequence:

- Seal the joint between the window frame and the internal linings
- Apply flexible sealant to all interfaces between the internal air barrier and the window / door frame
- Seal all penetrations through the air barrier using a flexible sealant

Results:

Description	Internal Blockwork Conductivity (W/mK)		
	0.15	0.51	1.13
Linear Thermal Transmittance ψ (W/mK)	0.209	0.270	0.297
Temperature Factor (f)	0.944	0.923	0.920

E3 - Sill

(30mm overlap between frame and cavity)

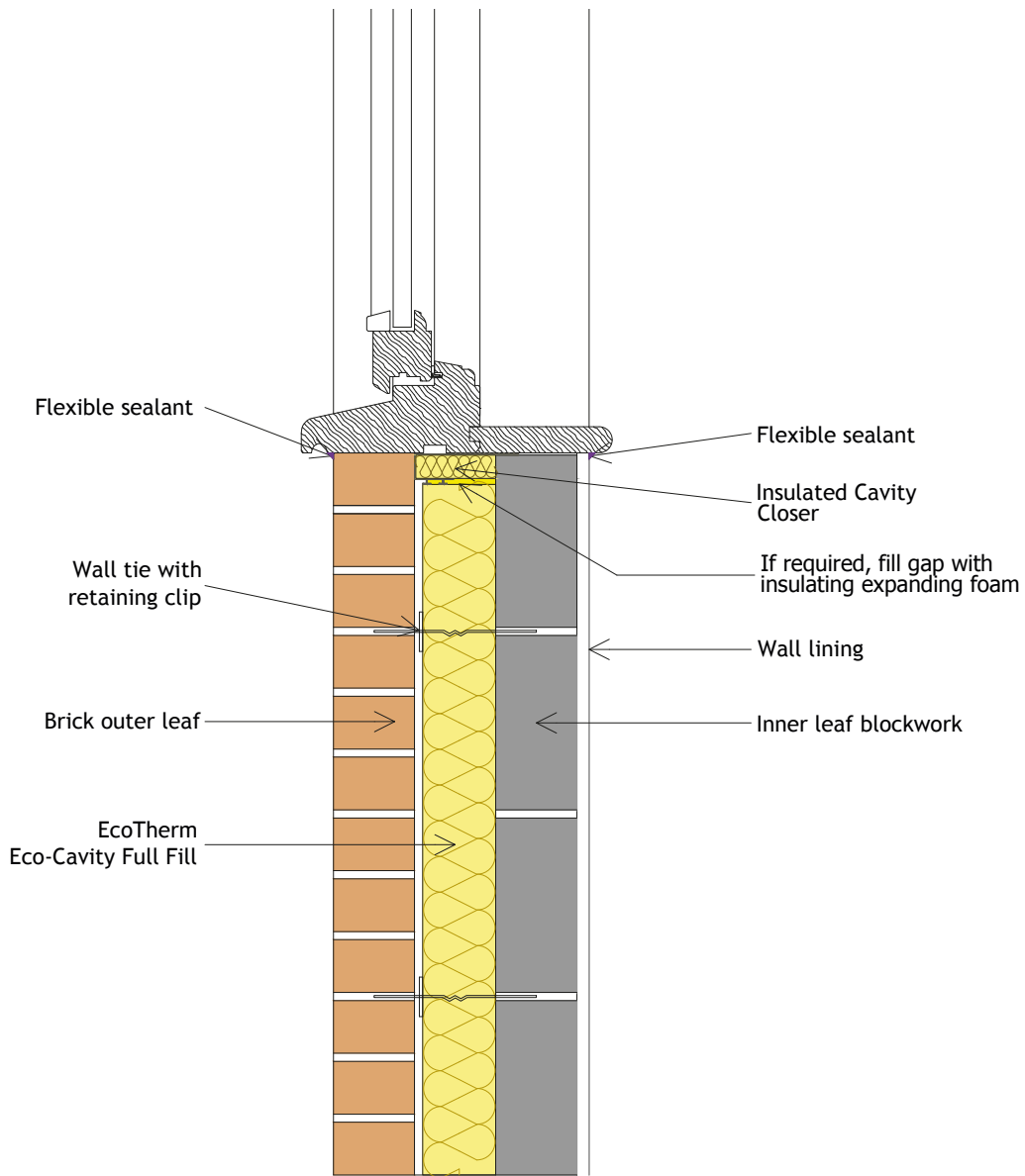

General Construction Specification:

Wall lining; inner leaf blockwork; Eco-Cavity Full Fill board;
10mm residual cavity; brickwork

U-value Range Covered:

Inner Block Density	U-value achieved
0.15 W/mK	0.18 W/m ² K
0.51 W/mK	0.19 W/m ² K
1.13 W/mK	0.20 W/m ² K

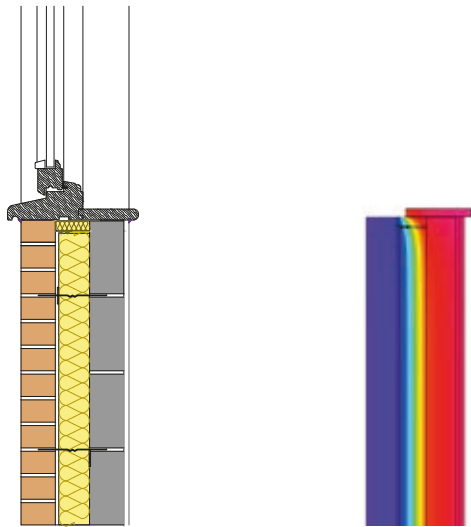

Thermal Performance Process Sequence:

- Ensure cavity closer is installed to close cavity
- Ensure Eco-Cavity Full Fill board is in contact with full length of cavity closer, if required, fill gap with insulating expanding foam
- Ensure there are no gaps in the Eco-Cavity Full Fill board
- Ensure window frame overlaps the cavity closer by no less than 30mm
- Ensure the Eco-Cavity Full Fill board is firmly held against the inner leaf of blockwork
- Ensure cavity and wall ties are kept clean of mortar or other debris during construction
- T&G edges to be tightly interlocked
- T&G edges (tongue) to be trimmed at interfaces to form a tight butt edge
- For fully overlapped / checked reveals ensure the window / door frame overlaps the insulated cavity closer fully / by no less than 80mm. All Psi values will be at least as good as the normal overlap

Air Barrier Process Sequence:

- Apply flexible sealant to all interfaces between the internal air barrier and the window / door frame
- Seal all penetrations through the air barrier using a flexible sealant
- Seal the junction between the internal lining and the window sill board (if used)
- Seal the junction between the window sill board and the window frame member

Results:

Description	Internal Blockwork Conductivity (W/mK)		
	0.15	0.51	1.13
Linear Thermal Transmittance ψ (W/mK)	0.018	0.017	0.017
Temperature Factor (f)	0.911	0.912	0.912

E4 - Jamb

(30mm overlap between frame and cavity)

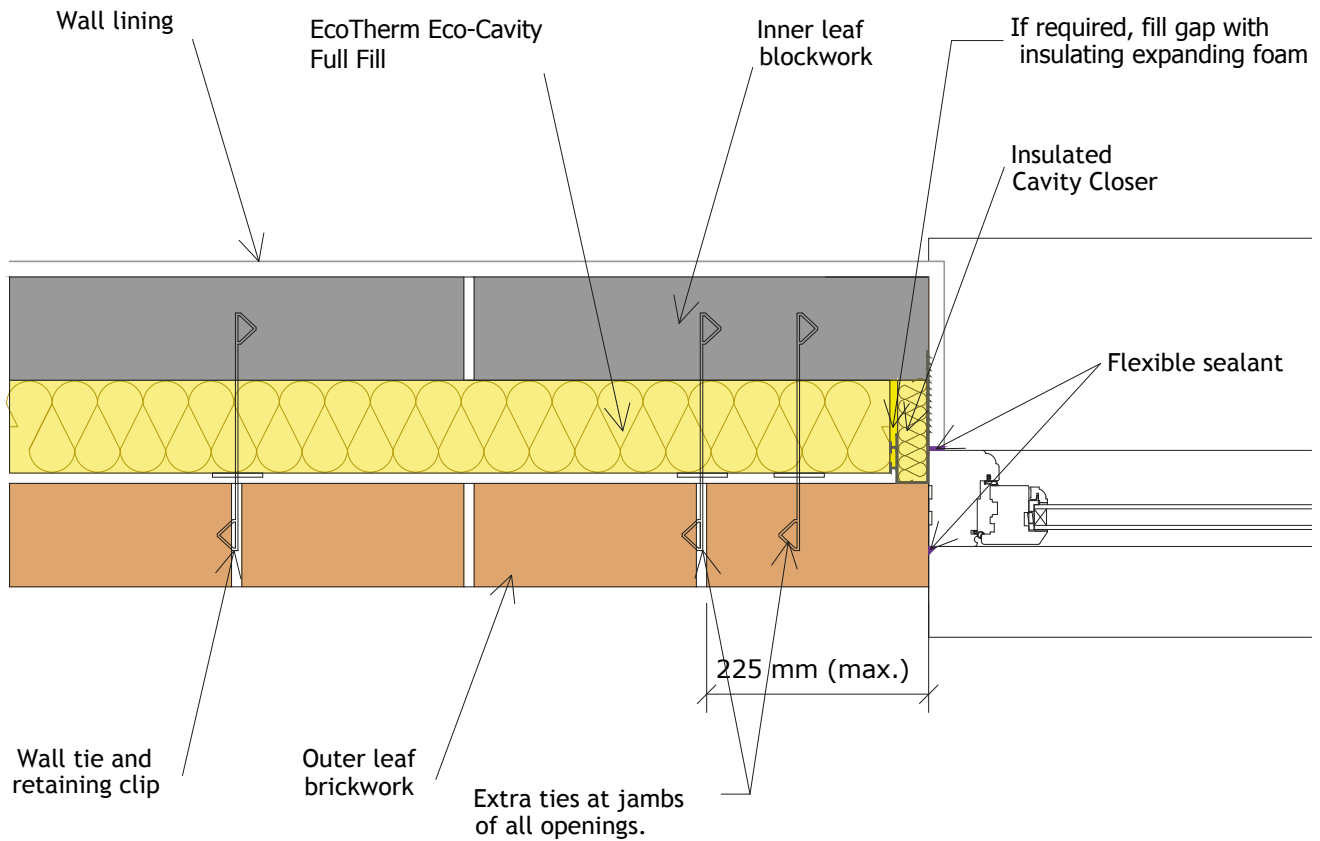

General Construction Specification:

Wall lining; inner leaf blockwork; Eco-Cavity Full Fill board; 10mm residual cavity; brickwork

U-value Range Covered:

Inner Block Density	U-value achieved
0.15 W/mK	0.18 W/m ² K
0.51 W/mK	0.19 W/m ² K
1.13 W/mK	0.20 W/m ² K

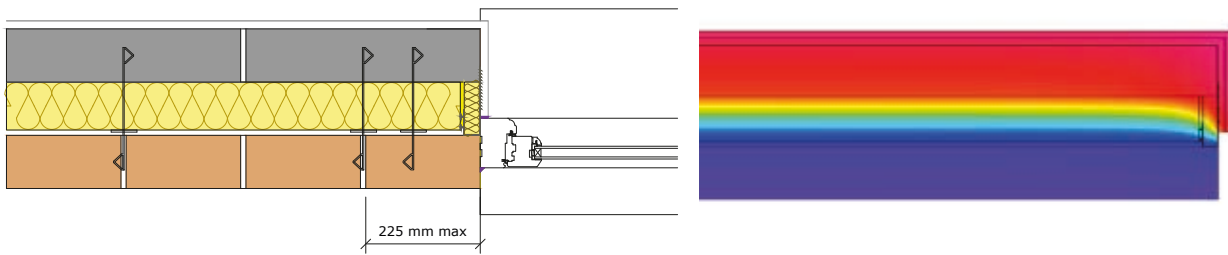

Thermal Performance Process Sequence:

- Ensure cavity closer is installed to close cavity
- Ensure Eco-Cavity Full Fill board is in contact with full length of cavity closer, if required, fill gap with insulating expanding foam
- Ensure there are no gaps in the Eco-Cavity Full Fill board
- Ensure window / door frame overlaps the cavity closer by no less than 30mm
- Ensure the Eco-Cavity Full Fill board is firmly held against the inner leaf of blockwork
- Ensure cavity and wall ties are kept clean of mortar or other debris during construction
- T&G edges to be tightly interlocked
- T&G edges (tongue) to be trimmed at interfaces to form a tight butt edge
- For fully overlapped / checked reveals ensure the window / door frame overlaps the insulated cavity closer fully /by no less than 80mm. All Psi values will be at least as good as the normal overlap
- At the vertical edges of openings and at vertical unreturned or unbounded edges (for example at movement joints and up the sloping verge of gable walls), additional wall ties should be used at a rate of one tie per 300mm height or equivalent, placed not more than 225mm from the edge
- Another solution would be to have an additional wall tie included within 225mm of the opening / vertical edge on each board course (450mm) level to satisfy the structural requirements of the wall. As the boards are 450mm in height having ties at 300mm centres will penetrate the board which may introduce an unacceptable risk of water penetration, therefore place additional ties on each board course to compensate

Air Barrier Process Sequence:

- Apply flexible sealant to all interfaces between the internal air barrier and the window / door frame
- Seal all penetrations through the air barrier using a flexible sealant
- Seal the junction between the internal lining and the window / door frame

Results:

Description	Internal Blockwork Conductivity (W/mK)		
	0.15	0.51	1.13
Linear Thermal Transmittance ψ (W/mK)	0.019	0.018	0.017
Temperature Factor (f)	0.925	0.926	0.926

E5 - Ground Floor

(solid concrete - insulation below screed)

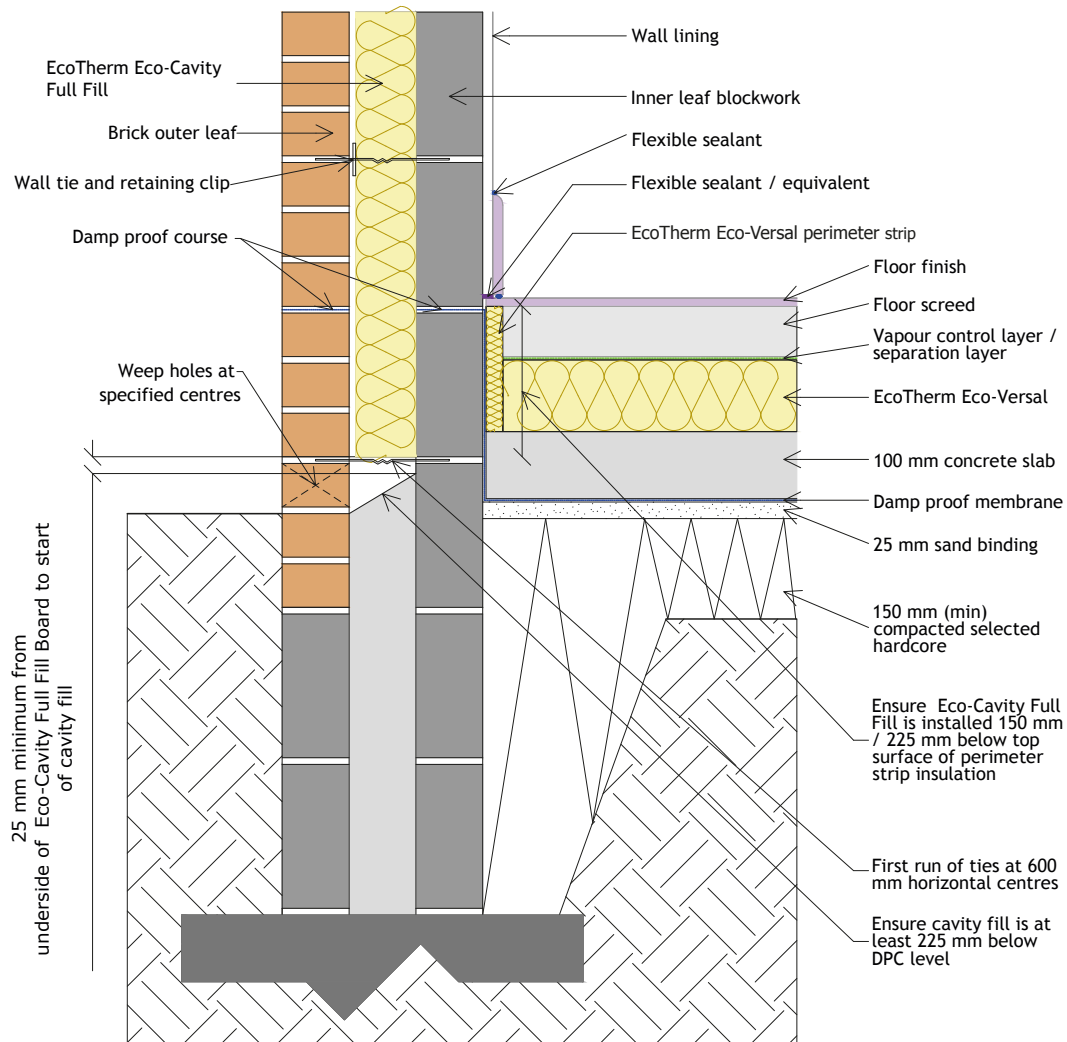

General Construction Specification:

Wall lining; inner leaf blockwork; Eco-Cavity Full Fill board;
10mm residual cavity; brickwork

U-value Range Covered:

Inner Block Density	U-value achieved
0.15 W/mK	0.18 W/m ² K
0.51 W/mK	0.19 W/m ² K
1.13 W/mK	0.20 W/m ² K

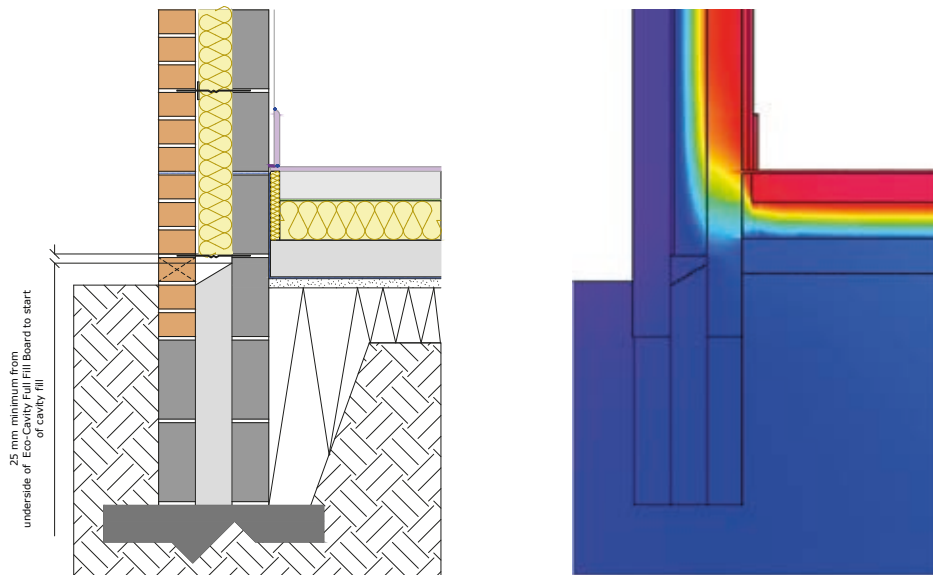

Thermal Performance Process Sequence:

- Install 25mm (min.) Eco-Versal vertically around the perimeter of the floor. Install the upstand insulation so that it is flush with the floor screed. Eco-Versal floor or vertical perimeter insulation must tightly abut the inner leaf of blockwork
- Ensure the Eco-Cavity Full Fill board is firmly held against the inner leaf of blockwork
- Ensure the Eco-Cavity Full Fill wall insulation is installed at least 150mm / 225mm (150mm for UK and 225mm for Republic of Ireland) below the top surface of the Eco-Versal perimeter insulation
- Ensure cavity and wall ties are kept clean of mortar or other debris during construction
- T&G edges to be tightly interlocked
- T&G edges (tongue) to be trimmed at interfaces to form a tight butt edge

Air Barrier Process Sequence:

- Apply flexible sealant between the wall lining and floor lining
- Apply flexible sealant between the skirting board and floor screed / finish
- Seal all penetrations through the air barrier using a flexible sealant

Results:

Description	Internal Blockwork Conductivity (W/mK)		
	0.15	0.51	1.13
Linear Thermal Transmittance ψ (W/mK)	0.11	0.161	0.222
Temperature Factor (f)	0.912	0.898	0.885

E5 - Ground Floor

(beam and block - parallel)

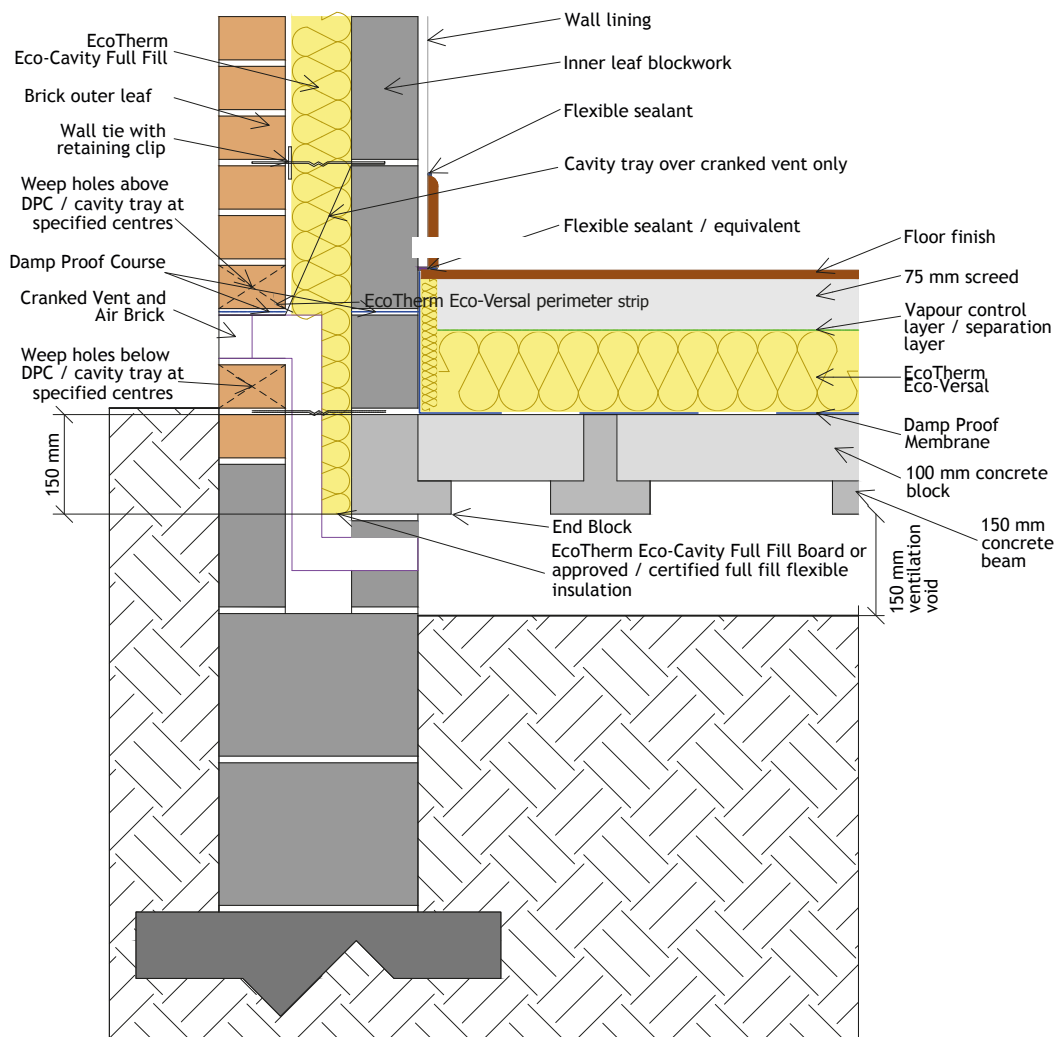

General Construction Specification:

Wall lining; inner leaf blockwork; Eco-Cavity Full Fill board;
10mm residual cavity; brickwork

U-value Range Covered:

Inner Block Density	U-value achieved
0.15 W/mK	0.18 W/m ² K
0.51 W/mK	0.19 W/m ² K
1.13 W/mK	0.20 W/m ² K

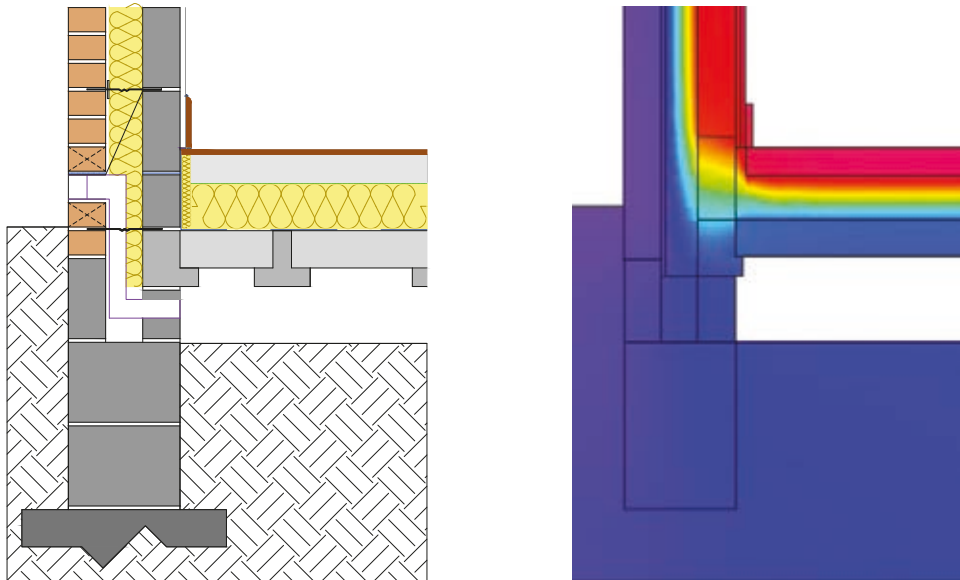

Thermal Performance Process Sequence:

- Install 25mm (min.) Eco-Versal vertically around the perimeter of the floor. Install the upstand insulation so that it is flush with the floor screed. Eco-Versal floor or vertical perimeter insulation must tightly abut the inner leaf of blockwork
- Ensure the Eco-Cavity Full Fill board is firmly held against the inner leaf of blockwork
- Ensure the Eco-Cavity Full Fill wall insulation is installed at least 150mm below the top surface of the floor beam / bottom of the floor insulation
- Ensure cavity and wall ties are kept clean of mortar or other debris during construction
- T&G edges to be tightly interlocked
- T&G edges (tongue) to be trimmed at interfaces to form a tight butt edge

Air Barrier Process Sequence:

- Apply flexible sealant between the wall lining and floor lining
- Apply flexible sealant between the skirting board and floor screed / finish
- Seal all penetrations through the air barrier using a flexible sealant

Results:

Description	Internal Blockwork Conductivity (W/mK)		
	0.15	0.51	1.13
Linear Thermal Transmittance ψ (W/mK)	0.075	0.080	0.083
Temperature Factor (f)	0.943	0.949	0.951

E5 - Ground Floor

(beam and block - perpendicular)

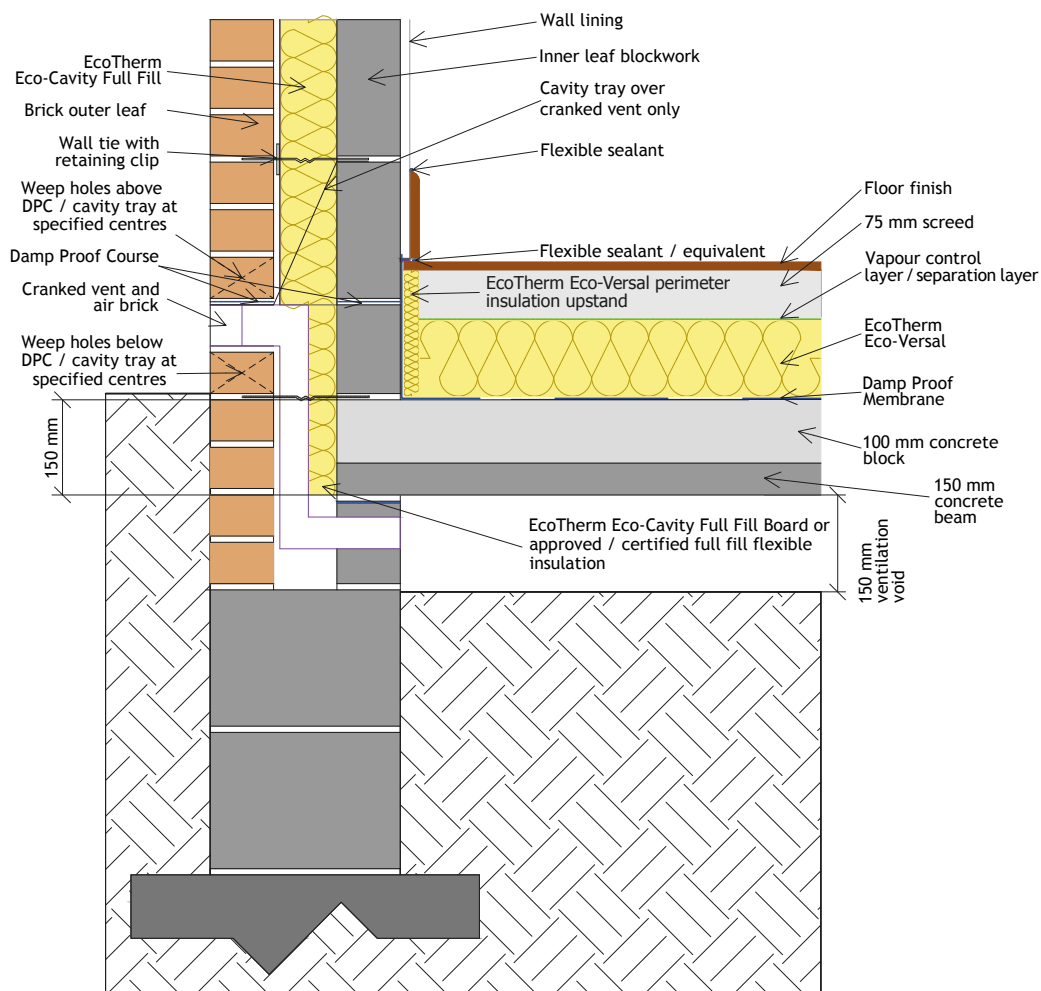

General Construction Specification:

Wall lining; inner leaf blockwork; Eco-Cavity Full Fill board; 10mm residual cavity; brickwork

U-value Range Covered:

Inner Block Density	U-value achieved
0.15 W/mK	0.18 W/m ² K
0.51 W/mK	0.19 W/m ² K
1.13 W/mK	0.20 W/m ² K

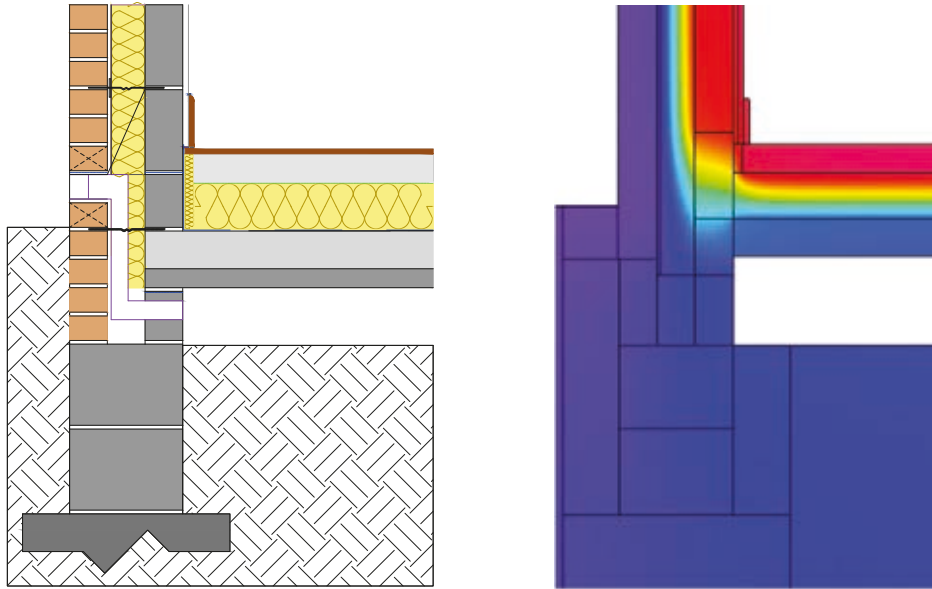

Thermal Performance Process Sequence:

- Install 25mm (min.) Eco-Versal vertically around the perimeter of the floor. Install the upstand insulation so that it is flush with the floor screed. Eco-Versal floor or vertical perimeter insulation must tightly abut the inner leaf of blockwork
- Ensure the Eco-Cavity Full Fill board is firmly held against the inner leaf of blockwork
- Ensure the Eco-Cavity Full Fill wall insulation is installed at least 150mm / 225mm (150mm for UK and 225mm for Republic of Ireland) below the top surface of the floor beam / bottom of the floor insulation
- Ensure cavity and wall ties are kept clean of mortar or other debris during construction
- T&G edges to be tightly interlocked
- T&G edges (tongue) to be trimmed at interfaces to form a tight butt edge

Air Barrier Process Sequence:

- Apply flexible sealant between the wall lining and floor lining
- Apply flexible sealant between the skirting board and floor screed / finish
- Seal all penetrations through the air barrier using a flexible sealant

Results:

Description	Internal Blockwork Conductivity (W/mK)		
	0.15	0.51	1.13
Linear Thermal Transmittance ψ (W/mK)	0.041	0.045	0.048
Temperature Factor (f)	0.939	0.943	0.946

E6 - Intermediate Floor within a Dwelling

(concrete)

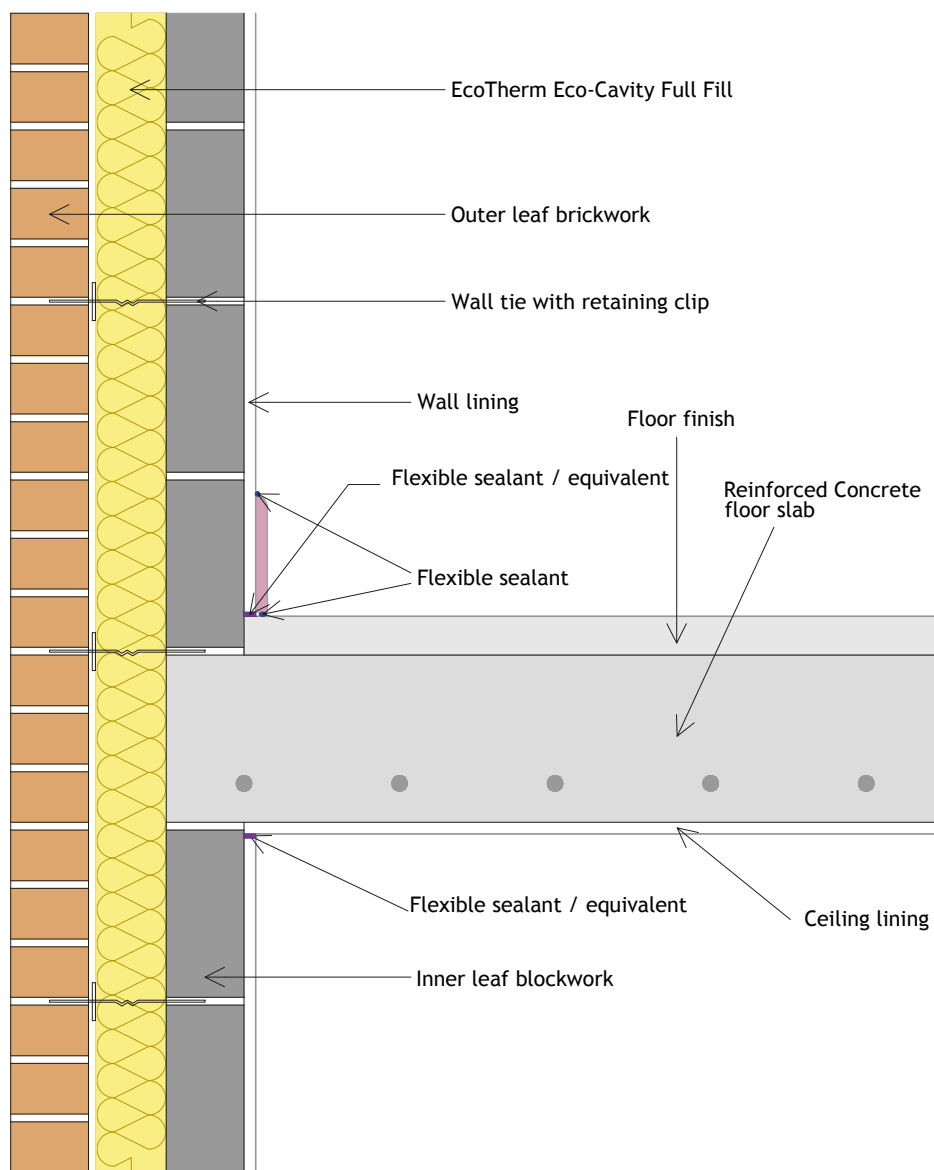

General Construction Specification:

Wall lining; inner leaf blockwork; Eco-Cavity Full Fill board;
10mm residual cavity; brickwork

U-value Range Covered:

Inner Block Density	U-value achieved
0.15 W/mK	0.18 W/m ² K
0.51 W/mK	0.19 W/m ² K
1.13 W/mK	0.20 W/m ² K

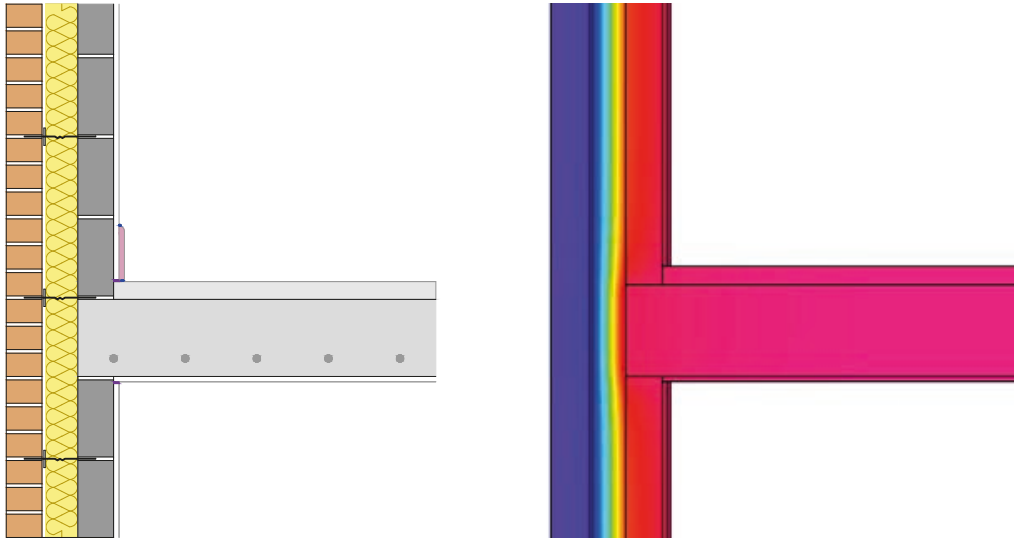

Thermal Performance Process Sequence:

- Ensure the Eco-Cavity Full Fill board is firmly held against the inner leaf of blockwork
- Continue the Eco-Cavity Full Fill wall insulation across the intermediate floor abutment zone
- Ensure cavity and wall ties are kept clean of mortar or other debris during construction
- T&G edges to be tightly interlocked
- T&G edges (tongue) to be trimmed at interfaces to form a tight butt edge

Air Barrier Process Sequence:

- Seal between the wall lining and floor screed lining with flexible sealant or plaster / screed mortar
- Apply flexible sealant between the wall lining and ceiling lining with flexible sealant or plaster mortar
- Apply flexible sealant between the skirting board and floor screed / finish
- Seal all penetrations through the air barrier using a flexible sealant or plaster mortar
- Ensure a continuous bed of mortar between the floor slab and blockwork

Results:

Description	Internal Blockwork Conductivity (W/mK)		
	0.15	0.51	1.13
Linear Thermal Transmittance ψ (W/mK)	0.013	0.007	0.006
Temperature Factor (f)	0.974	0.971	0.968

E6 - Intermediate Floor within a Dwelling

(timber)

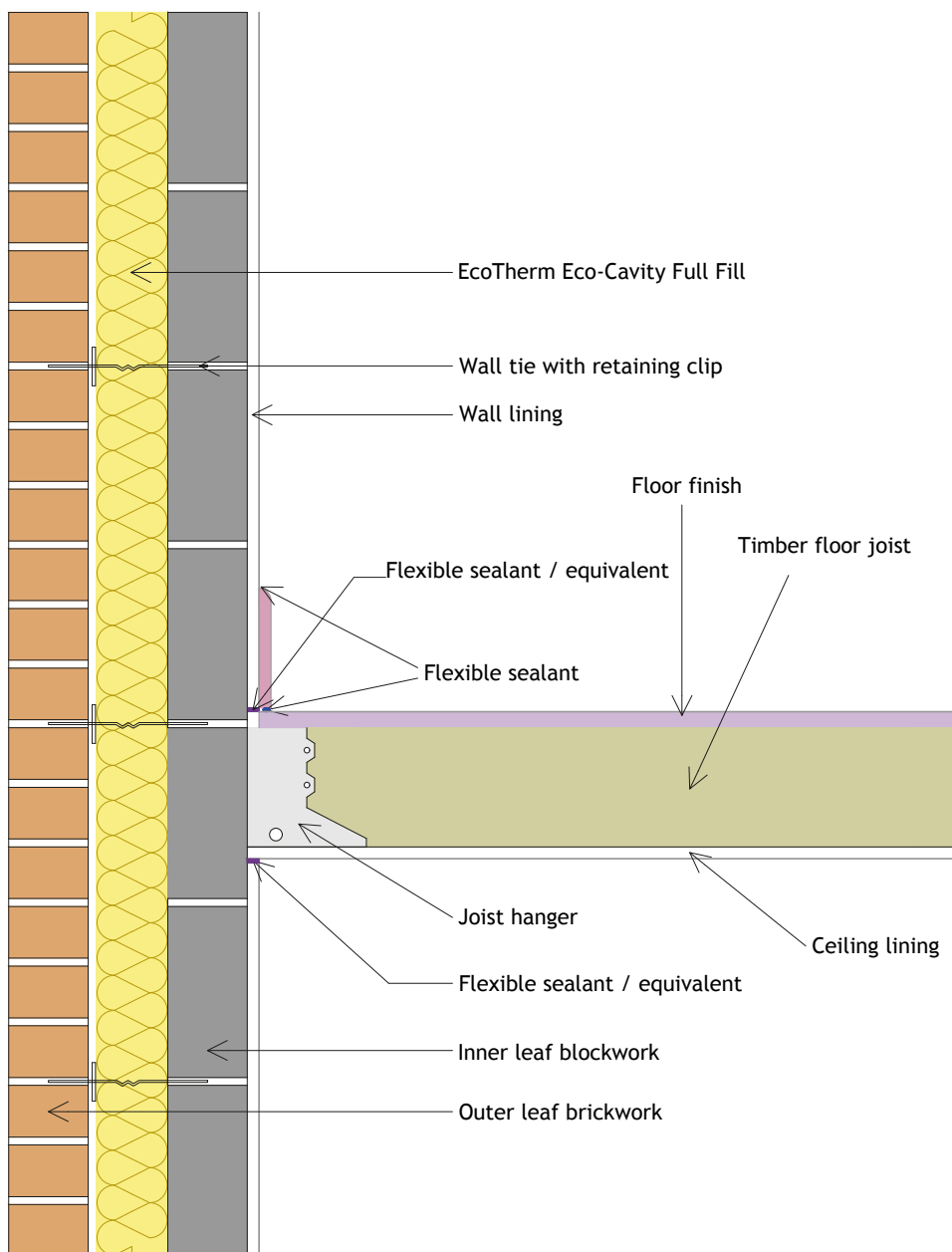

General Construction Specification:

Wall lining; inner leaf blockwork; Eco-Cavity Full Fill board;
10mm residual cavity; brickwork

U-value Range Covered:

Inner Block Density	U-value achieved
0.15 W/mK	0.18 W/m ² K
0.51 W/mK	0.19 W/m ² K
1.13 W/mK	0.20 W/m ² K

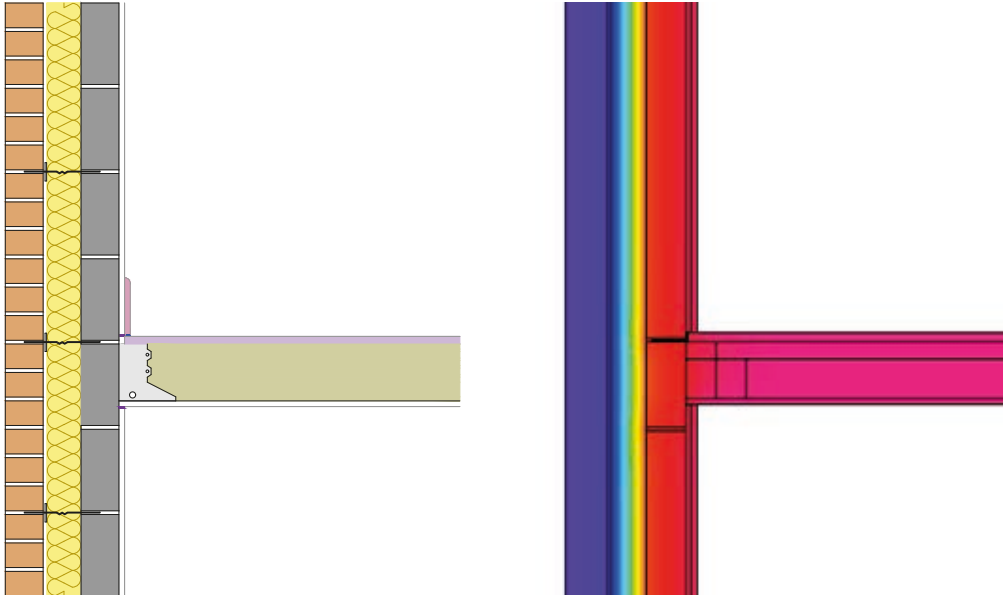

Thermal Performance Process Sequence:

- Ensure the Eco-Cavity Full Fill board is firmly held against the inner leaf of blockwork
- Continue the Eco-Cavity Full Fill wall insulation across the intermediate floor abutment zone
- Ensure cavity and wall ties are kept clean of mortar or other debris during construction
- T&G edges to be tightly interlocked
- T&G edges (tongue) to be trimmed at interfaces to form a tight butt edge

Air Barrier Process Sequence:

- Seal between the wall lining and floor lining with flexible sealant
- Apply flexible sealant between the wall lining and ceiling lining with flexible sealant
- Apply flexible sealant between the skirting board and floor lining / finish
- Seal all penetrations through the air barrier using a flexible sealant or plaster mortar

Results:

Description	Internal Blockwork Conductivity (W/mK)		
	0.15	0.51	1.13
Linear Thermal Transmittance ψ (W/mK)	0.00	0.00	0.00
Temperature Factor (f)	0.962	0.959	0.949

E7 - Party Floor between Dwellings

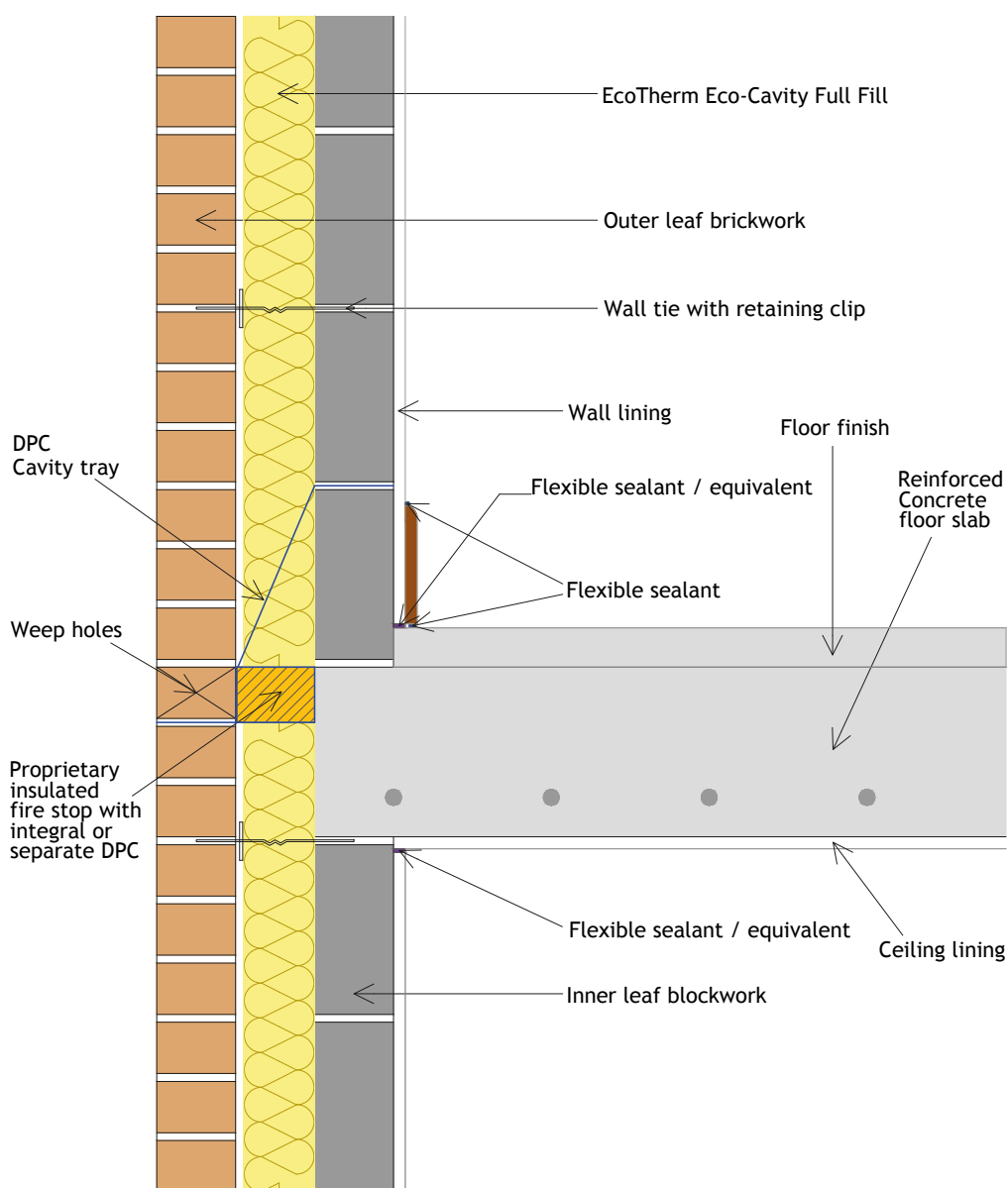

General Construction Specification:

Wall lining; inner leaf blockwork; Eco-Cavity Full Fill board; 10mm residual cavity; brickwork

U-value Range Covered:

Inner Block Density	U-value achieved
0.15 W/mK	0.18 W/m ² K
0.51 W/mK	0.19 W/m ² K
1.13 W/mK	0.20 W/m ² K

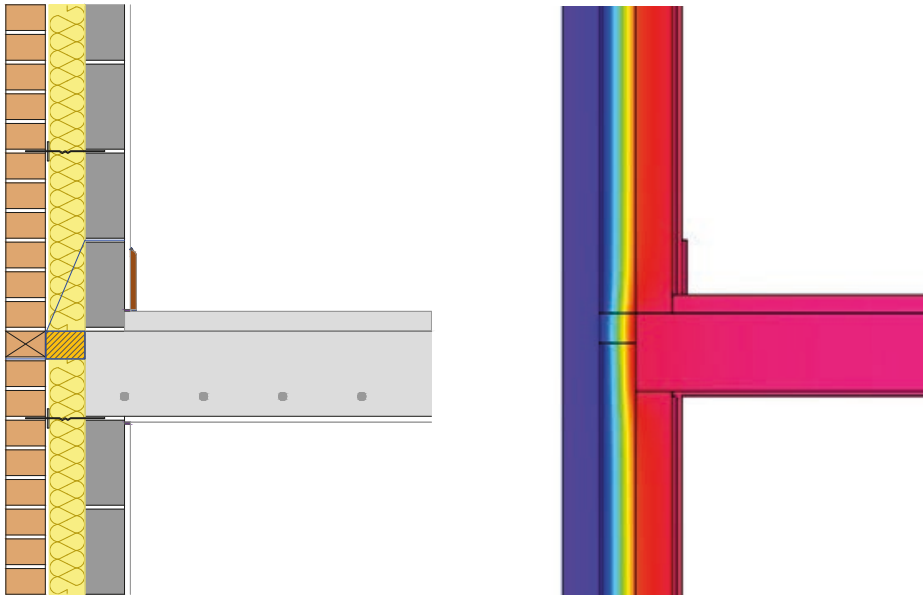

Thermal Performance Process Sequence:

- Ensure the Eco-Cavity Full Fill board is firmly held against the inner leaf of blockwork
- Continue the Eco-Cavity Full Fill wall insulation across the intermediate floor abutment zone
- Ensure cavity and wall ties are kept clean of mortar or other debris during construction
- Ensure Eco-Cavity Full Fill board is firmly held against / butted lightly to the fire stop
- T&G edges to be tightly interlocked
- T&G edges (tongue) to be trimmed at interfaces to form a tight butt edge

Air Barrier Process Sequence:

- Seal between the wall lining and floor lining with flexible sealant or plaster / screed mortar
- Seal between the wall lining and ceiling with flexible sealant or plaster mortar
- Apply flexible sealant between the skirting board and floor lining / finish
- Seal all penetrations through the air barrier using a flexible sealant or plaster mortar
- Ensure a continuous bed of mortar between the floor slab and blockwork

Results:

Description	Internal Blockwork Conductivity (W/mK)		
	0.15	0.51	1.13
Linear Thermal Transmittance ψ (W/mK)	0.035	0.034	0.035
Temperature Factor (f)	0.976	0.975	0.973

E10 - Eaves

(insulation at ceiling level)

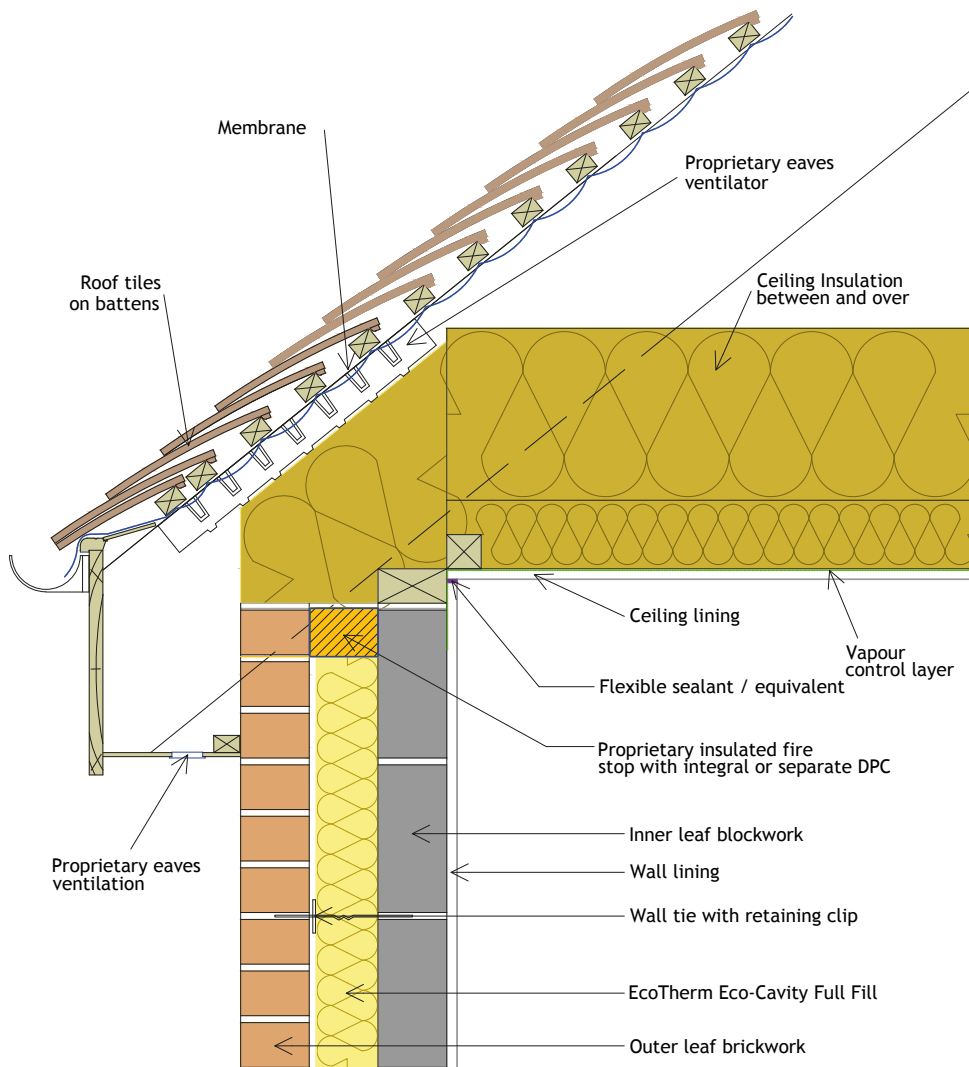

General Construction Specification:

Wall lining; inner leaf blockwork; Eco-Cavity Full Fill board; 10mm residual cavity; brickwork

U-value Range Covered:

Inner Block Density	U-value achieved
0.15 W/mK	0.18 W/m ² K
0.51 W/mK	0.19 W/m ² K
1.13 W/mK	0.20 W/m ² K

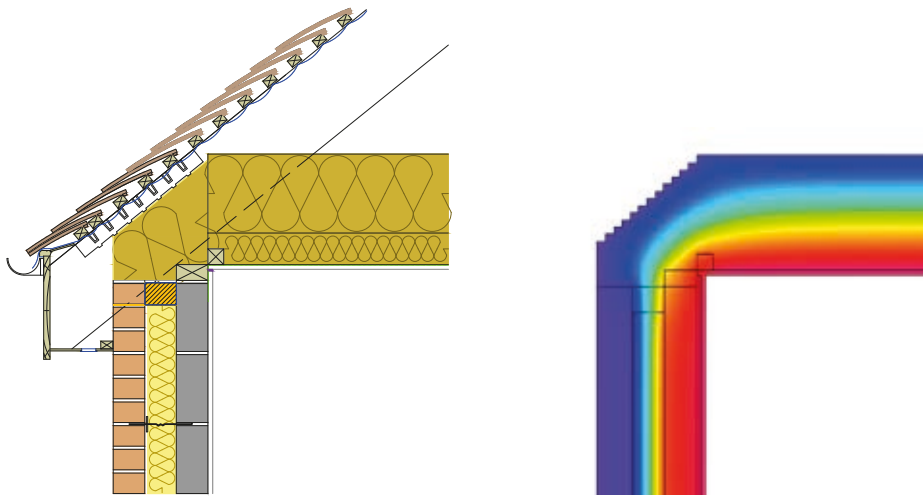

Thermal Performance Process Sequence:

- Ensure the Eco-Cavity Full Fill board is firmly held against the inner leaf of blockwork
- Ensure the gap between the wall plate and eaves ventilator is completely filled with flexible insulation. Flexible insulation to have an R-Value of 1.2 m²K/W or higher
- Ensure the flexible insulation is tucked down the head of the cavity to enable continuity of the flexible insulation and the Eco-Cavity Full Fill board Insulation throughout the junction
- Ensure the full depth of ceiling insulation, between and over joist ceiling insulation, abuts the eaves insulation
- Ensure the Eco-Cavity Full Fill board and eaves insulation is firmly held against / butted tight against the fire stop
- Ensure cavity and wall ties are kept clean of mortar or other debris during construction
- T&G edges to be tightly interlocked
- T&G edges (tongue) to be trimmed at interfaces to form a tight butt edge

Air Barrier Process Sequence:

- Bed the wall plate on a continuous layer of mortar
- Seal the gap between the wall and ceiling linings with flexible sealant or plaster mortar
- Seal all penetrations through the air barrier using a flexible sealant or plaster mortar

Results:

Description	Internal Blockwork Conductivity (W/mK)		
	0.15	0.51	1.13
Linear Thermal Transmittance ψ (W/mK)	0.029	0.032	0.034
Temperature Factor (f)	0.933	0.939	0.942

E11 - Eaves

(insulation at rafter level)

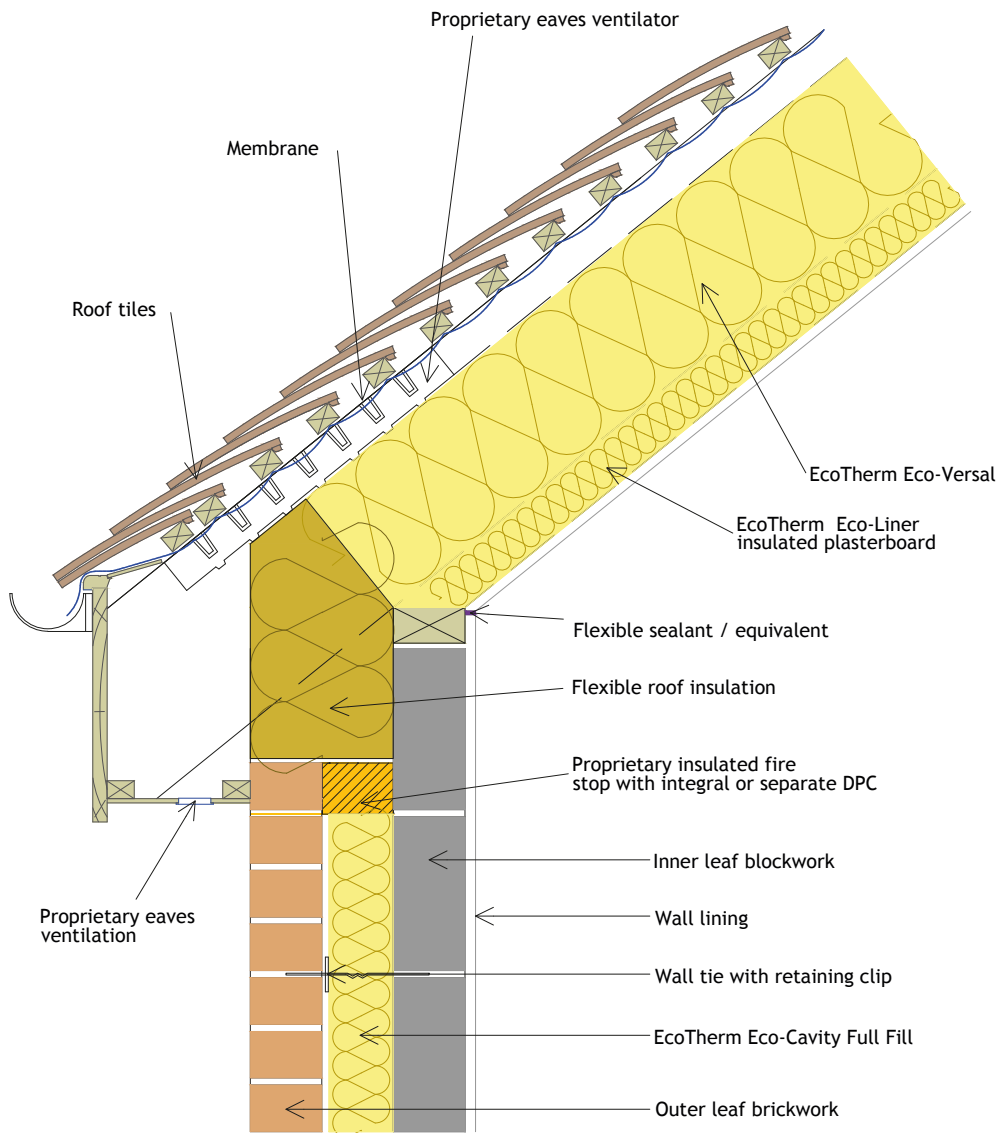

General Construction Specification:

Wall lining; inner leaf blockwork; Eco-Cavity Full Fill board;
10mm residual cavity; brickwork

U-value Range Covered:

Inner Block Density	U-value achieved
0.15 W/mK	0.18 W/m ² K
0.51 W/mK	0.19 W/m ² K
1.13 W/mK	0.20 W/m ² K

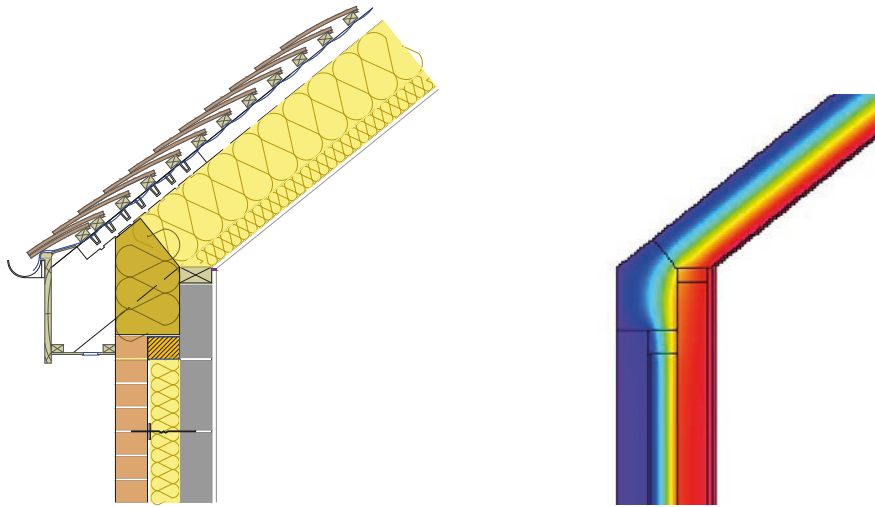

Thermal Performance Process Sequence:

- Ensure the Eco-Cavity Full Fill board is firmly held against the inner leaf of blockwork
- Ensure the gap between the wall plate and eaves ventilator is completely filled with flexible insulation. Flexible insulation to have an R-Value of 1.2 m²K/W or higher
- Ensure the flexible insulation is tucked down the head of the cavity to enable continuity of the flexible insulation and the Eco-Cavity Full Fill Insulation throughout the junction
- Ensure the full depth of ceiling insulation, between and over joist ceiling insulation, abuts the eaves insulation
- Ensure the Eco-Cavity Full Fill board is firmly held against / butted tight against the fire stop
- Ensure cavity and wall ties are kept clean of mortar or other debris during construction
- T&G edges to be tightly interlocked
- T&G edges (tongue) to be trimmed at interfaces to form a tight butt edge

Air Barrier Process Sequence:

- Bed the wall plate on a continuous layer of mortar
- Seal the gap between the wall and ceiling linings with flexible sealant or plaster mortar
- Seal all penetrations through the air barrier using a flexible sealant or plaster mortar

Results:

Description	Internal Blockwork Conductivity (W/mK)		
	0.15	0.51	1.13
Linear Thermal Transmittance ψ (W/mK)	0.025	0.028	0.029
Temperature Factor (f)	0.964	0.963	0.964

E12 - Gable

(insulation at ceiling level)

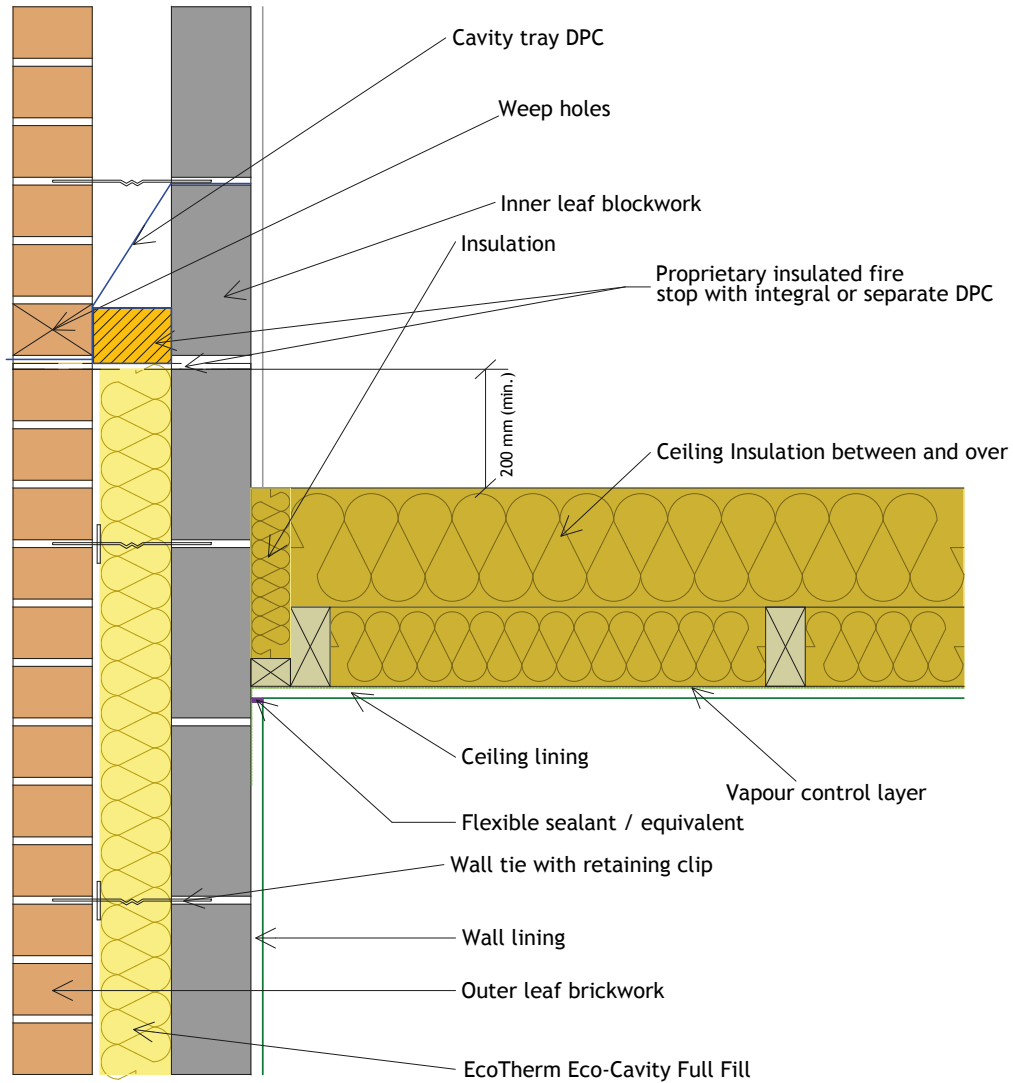

General Construction Specification:

Wall lining; inner leaf blockwork; Eco-Cavity Full Fill board; 10mm residual cavity; brickwork

U-value Range Covered:

Inner Block Density	U-value achieved
0.15 W/mK	0.18 W/m ² K
0.51 W/mK	0.19 W/m ² K
1.13 W/mK	0.20 W/m ² K

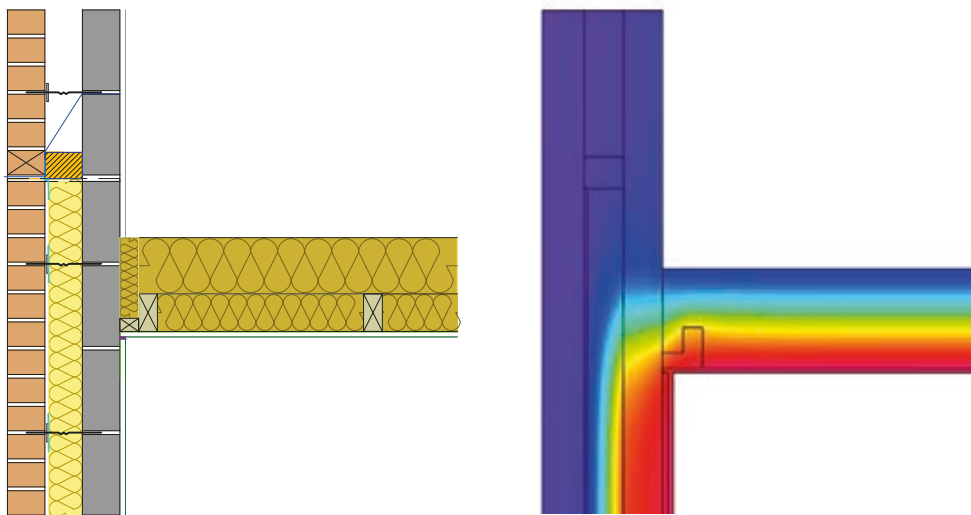

Thermal Performance Process Sequence:

- Ensure the Eco-Cavity Full Fill board is firmly held against the inner leaf of blockwork
- Pack flexible insulation between last truss / joist and gable wall
- Ensure the ceiling insulation over the truss / joist tightly abuts the flexible insulation packed between the last truss / joists
- Ensure the ceiling insulation between and over the truss / joists extends to the inner edge of the wall
- Ensure cavity and wall ties are kept clean of mortar or other debris during construction
- Ensure all Eco-Cavity Full Fill board joints are lightly butted
- Eco-Cavity Full Fill board to be installed a minimum of 200mm above the top surface of the ceiling insulation
- T&G edges to be tightly interlocked
- T&G edges (tongue) to be trimmed at interfaces to form a tight butt edge

Air Barrier Process Sequence:

- Seal the gap between the wall and ceiling linings with flexible sealant or plaster mortar
- Seal all penetrations through the air barrier using a flexible sealant or plaster mortar

Results:

Description	Internal Blockwork Conductivity (W/mK)		
	0.15	0.51	1.13
Linear Thermal Transmittance ψ (W/mK)	0.040	0.100	0.177
Temperature Factor (f)	0.909	0.873	0.845

E13 - Gable

(insulation at rafter level)

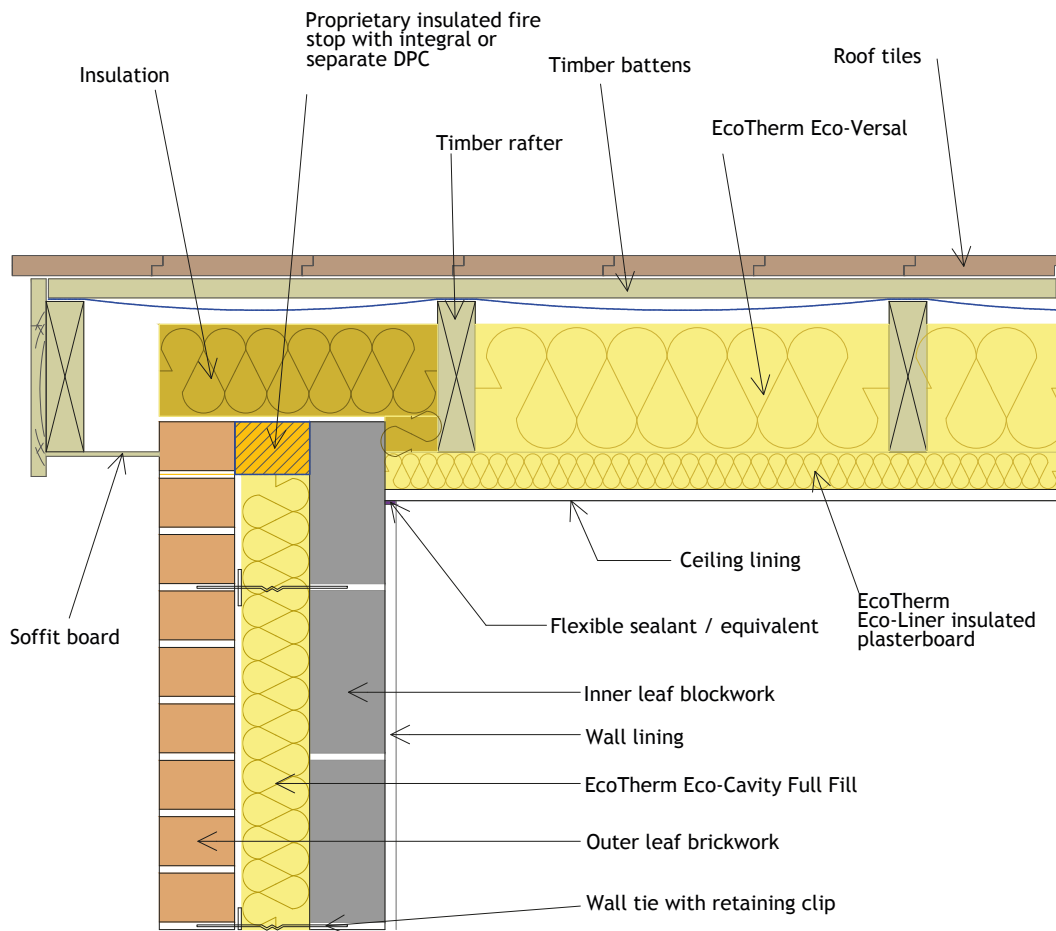

General Construction Specification:

Wall lining; inner leaf blockwork; Eco-Cavity Full Fill board; 10mm residual cavity; brickwork

U-value Range Covered:

Inner Block Density	U-value achieved
0.15 W/mK	0.18 W/m ² K
0.51 W/mK	0.19 W/m ² K
1.13 W/mK	0.20 W/m ² K

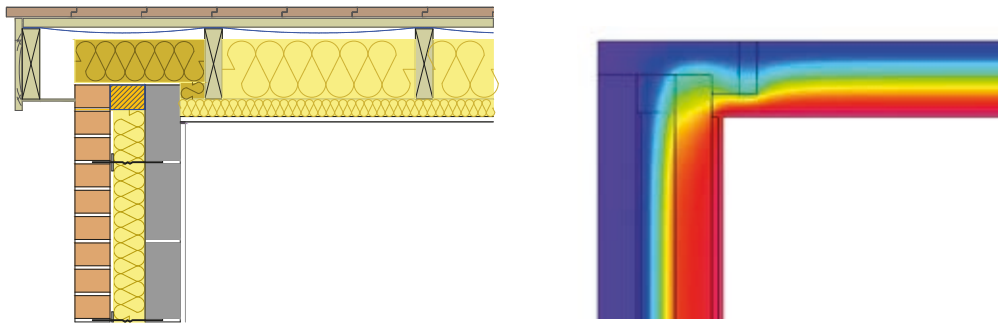

Thermal Performance Process Sequence:

- Ensure the Eco-Cavity Full Fill board is firmly held against the inner leaf of blockwork
- Ensure the gap between the wall plate and eaves ventilator is completely filled with flexible insulation. Flexible insulation to have an R-Value of 1.2 m²K/W or higher
- Ensure the flexible insulation is tucked down the head of the cavity to enable continuity of the flexible insulation and the Eco-Cavity Full Fill board Insulation throughout the junction
- Ensure the full depth of ceiling insulation, between and over joist ceiling insulation, abuts the eaves insulation
- Ensure the Eco-Cavity Full Fill board is firmly held against / butted tight against the fire stop
- Ensure cavity and wall ties are kept clean of mortar or other debris during construction
- T&G edges to be tightly interlocked
- T&G edges (tongue) to be trimmed at interfaces to form a tight butt edge

Air Barrier Process Sequence:

- Bed the wall plate on a continuous layer of mortar
- Seal the gap between the wall and ceiling linings with flexible sealant or plaster mortar
- Seal all penetrations through the air barrier using a flexible sealant or plaster mortar

Results:

Description	Internal Blockwork Conductivity (W/mK)		
	0.15	0.51	1.13
Linear Thermal Transmittance ψ (W/mK)	0.058	0.080	0.091
Temperature Factor (f)	0.913	0.909	0.916

E14 - Flat Roof

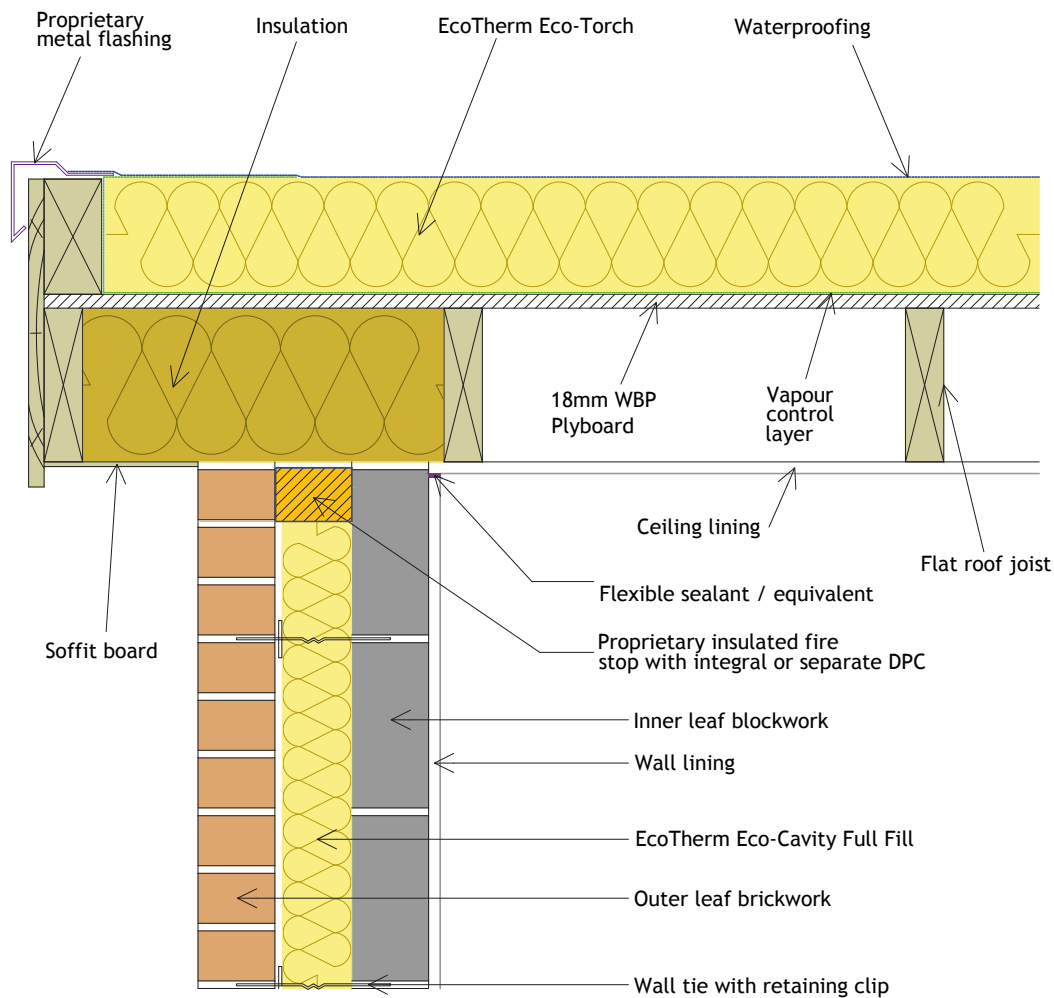

General Construction Specification:

Wall lining; inner leaf blockwork; Eco-Cavity Full Fill board; 10mm residual cavity; brickwork

U-value Range Covered:

Inner Block Density	U-value achieved
0.15 W/mK	0.18 W/m ² K
0.51 W/mK	0.19 W/m ² K
1.13 W/mK	0.20 W/m ² K

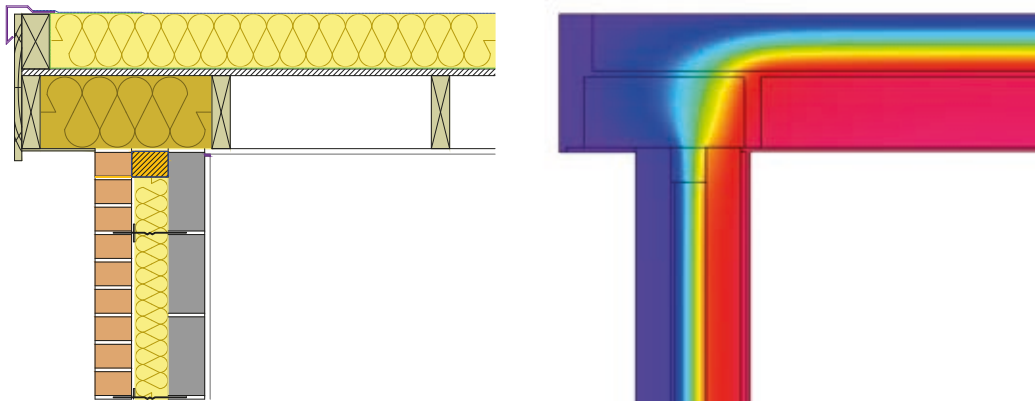

Thermal Performance Process Sequence:

- Ensure the Eco-Cavity Full Fill board is firmly held against the inner leaf of blockwork
- Ensure the Eco-Cavity Full Fill board is taken up level with the top of the wall and firmly held against / butted tight against the fire stop
- Pack flexible insulation between the last joist / gable ladder. Fully fill the void and ensure the insulation is in contact with the roof deck and cavity closer
- Ensure the EcoTherm Eco-Torch Warm Deck roof insulation extends to the edge of the roof
- Ensure cavity and wall ties are kept clean of mortar or other debris during construction
- Ensure all Eco-Cavity Full Fill board joints are lightly butted
- T&G edges to be tightly interlocked
- T&G edges (tongue) to be trimmed at interfaces to form a tight butt edge

Air Barrier Process Sequence:

- Seal the gap between the wall and ceiling linings with flexible sealant or plaster mortar
- Seal all penetrations through the air barrier using a flexible sealant or plaster mortar

Results:

Description	Internal Blockwork Conductivity (W/mK)		
	0.15	0.51	1.13
Linear Thermal Transmittance ψ (W/mK)	0.049	0.053	0.054
Temperature Factor (f)	0.959	0.957	0.958

E15 - Flat Roof with Parapet

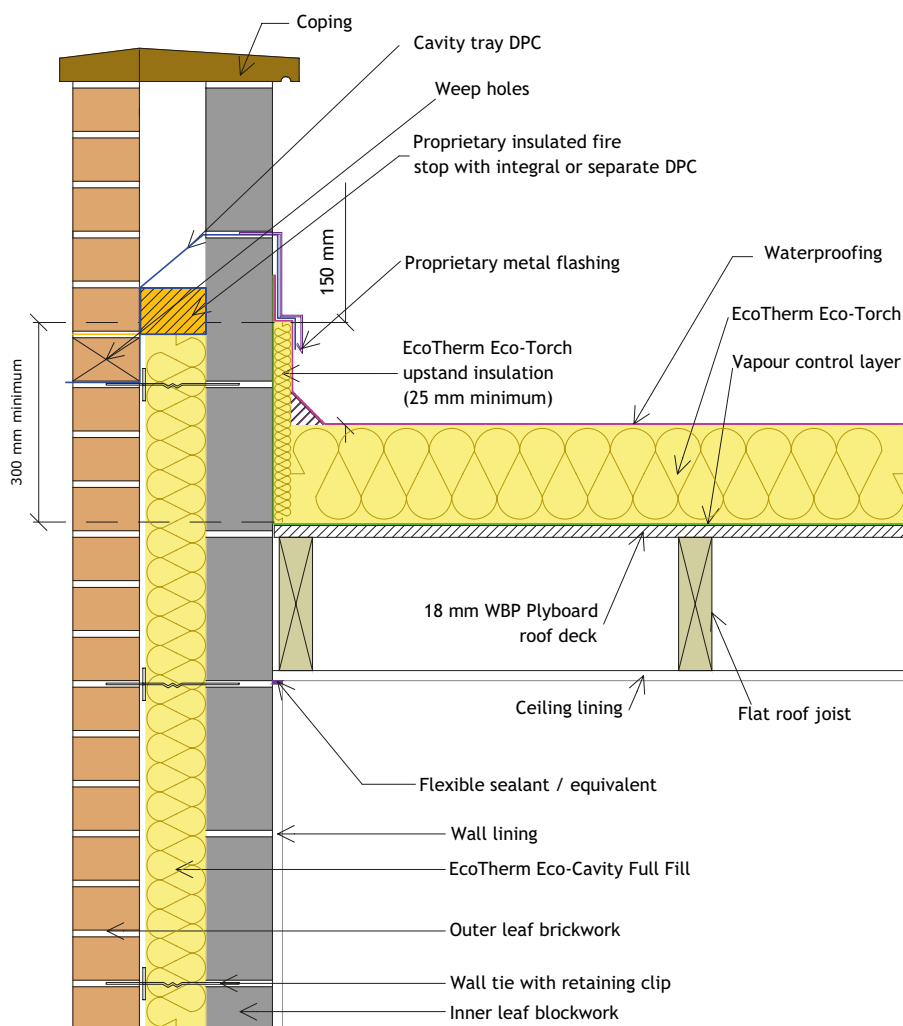

General Construction Specification:

Wall lining; inner leaf blockwork; Eco-Cavity Full Fill board;
10mm residual cavity; brickwork

U-value Range Covered:

Inner Block Density	U-value achieved
0.15 W/mK	0.18 W/m ² K
0.51 W/mK	0.19 W/m ² K
1.13 W/mK	0.20 W/m ² K

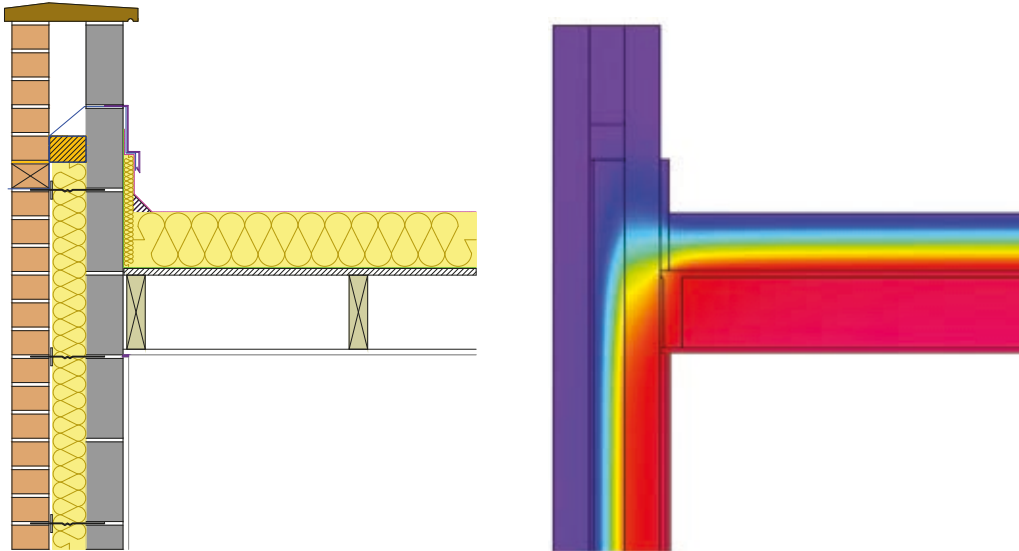

Thermal Performance Process Sequence:

- Ensure the Eco-Cavity Full Fill board is firmly held against the inner leaf of blockwork
- Install 25mm (min.) Eco-Torch upstand insulation around the parapet
- Ensure the Eco-Torch roof or upstand insulation tightly abuts the inner face of the parapet blockwork
- Ensure there is a distance of at least 300mm (min.) between the top of the Eco-Torch upstand insulation and the bottom of the Eco-Torch roof insulation
- Ensure cavity and wall ties are kept clean of mortar or other debris during construction
- Ensure the Eco-Cavity Full Fill board is firmly held against / butted lightly against fire stop
- T&G edges to be tightly interlocked
- T&G edges (tongue) to be trimmed at interfaces to form a tight butt edge

Air Barrier Process Sequence:

- Seal the gap between the wall and ceiling linings with flexible sealant or plaster mortar
- Seal all penetrations through the air barrier using a flexible sealant or plaster mortar

Results:

Description	Internal Blockwork Conductivity (W/mK)		
	0.15	0.51	1.13
Linear Thermal Transmittance ψ (W/mK)	0.075	0.129	0.199
Temperature Factor (f)	0.941	0.917	0.893

E16 - Corner

(normal)

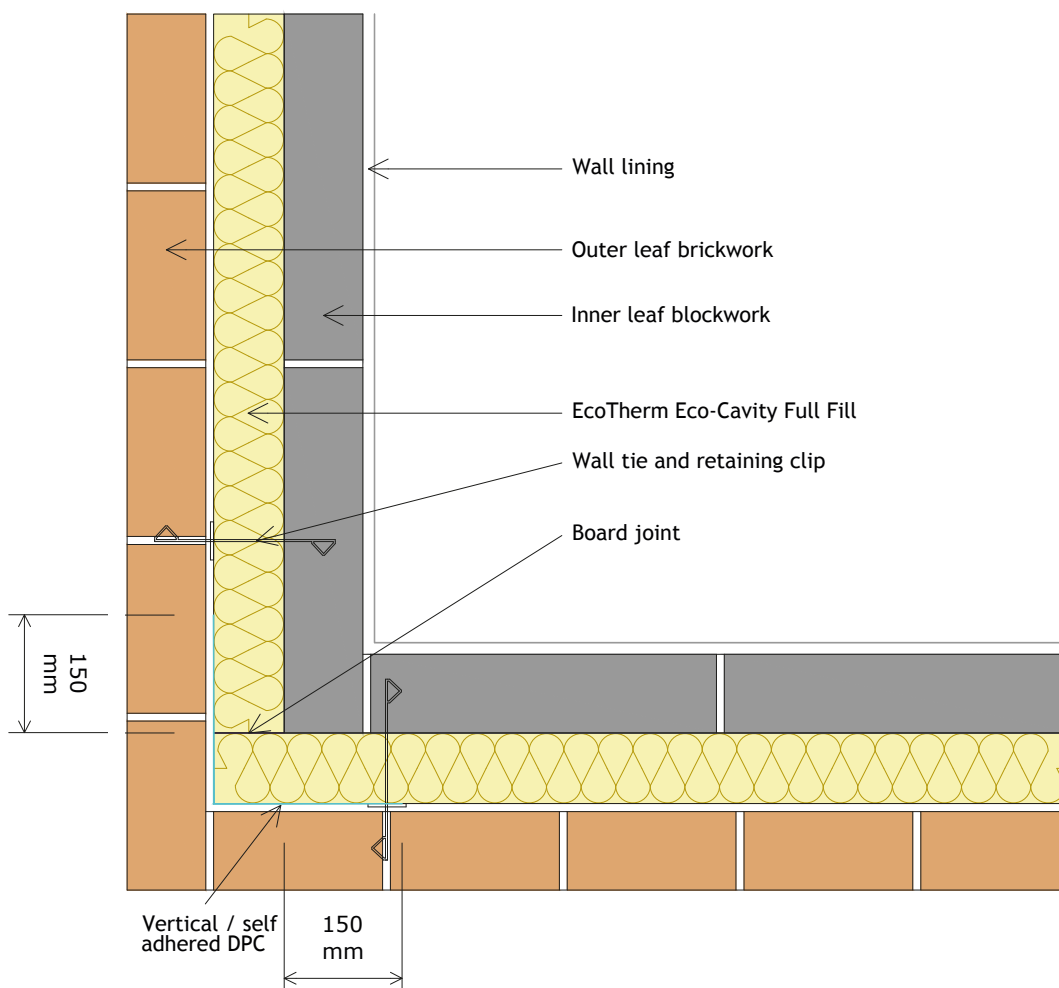

General Construction Specification:

Wall lining; inner leaf blockwork; Eco-Cavity Full Fill board; 10mm residual cavity; brickwork

U-value Range Covered:

Inner Block Density	U-value achieved
0.15 W/mK	0.18 W/m ² K
0.51 W/mK	0.19 W/m ² K
1.13 W/mK	0.20 W/m ² K

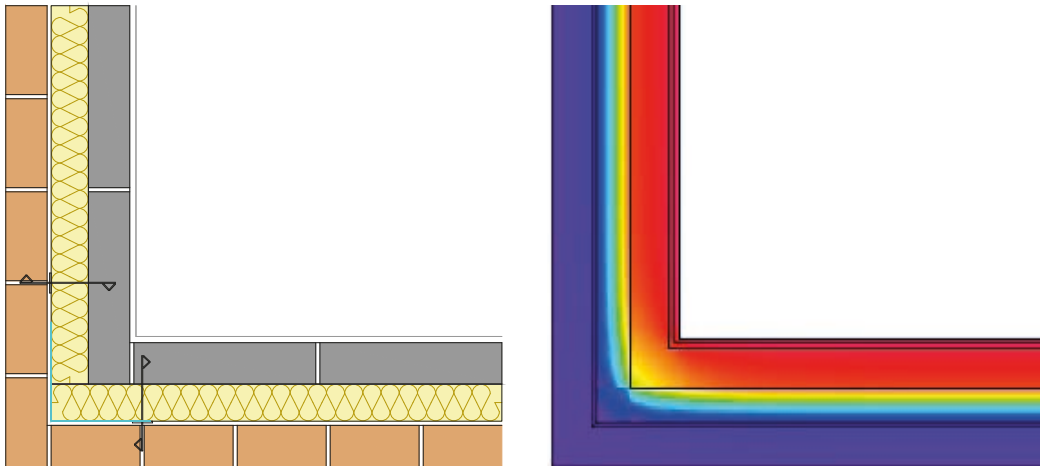

Thermal Performance Process Sequence:

- Ensure Eco-Cavity Full Fill board joints are staggered at the building corners
- Ensure the Eco-Cavity Full Fill board is firmly held against the inner leaf of blockwork
- Ensure cavity and wall ties are kept clean of mortar or other debris during construction
- T&G edges to be tightly interlocked
- T&G edges (tongue) to be trimmed at interfaces to form a tight butt edge
- Mitred corner joints are also acceptable, and will achieve the same thermal performance

Air Barrier Process Sequence:

- Seal the gap between the wall and ceiling linings with flexible sealant or plaster mortar
- Seal all penetrations through the air barrier using a flexible sealant

Results:

Description	Internal Blockwork Conductivity (W/mK)		
	0.15	0.51	1.13
Linear Thermal Transmittance ψ (W/mK)	0.037	0.047	0.050
Temperature Factor (f)	0.892	0.908	0.921

E17 - Corner

(inverted)

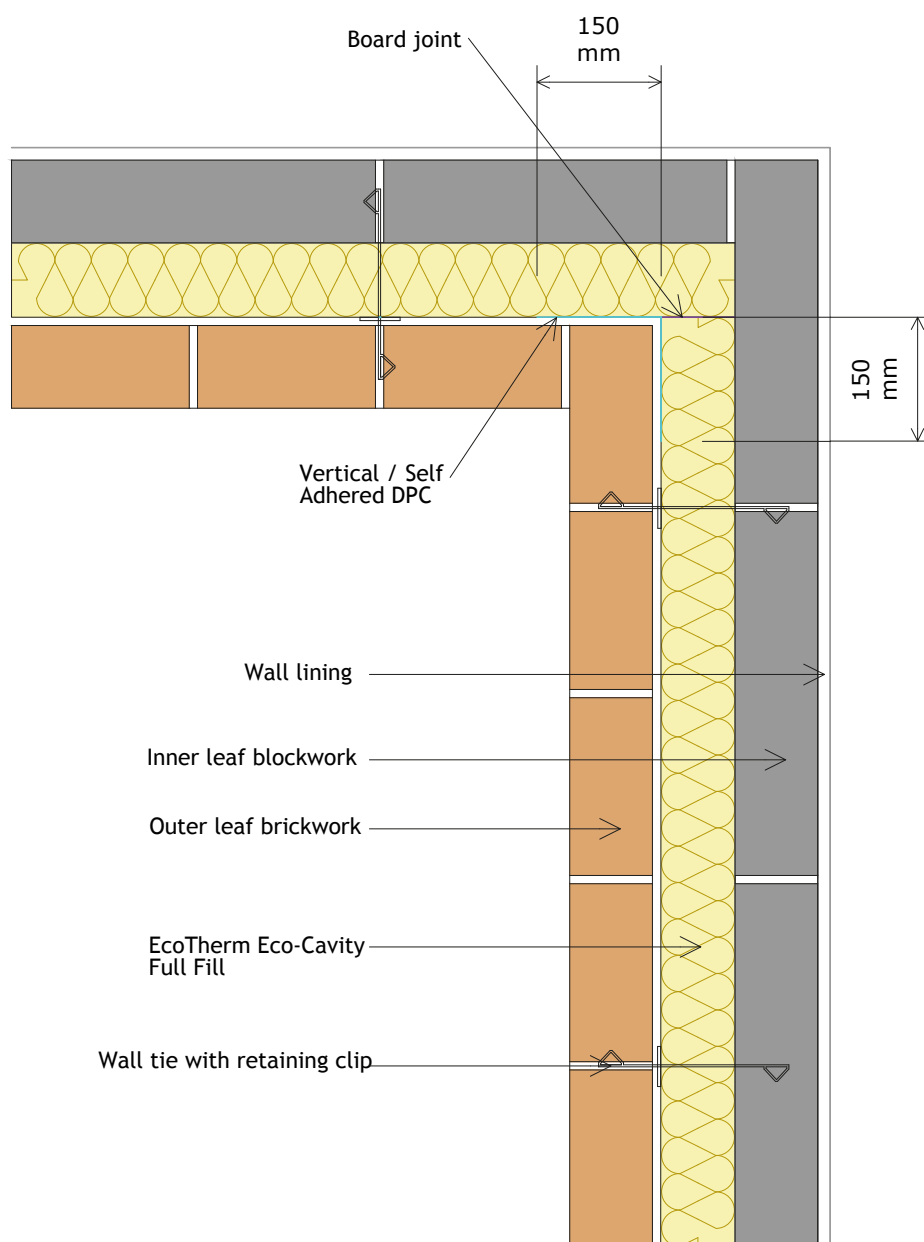

General Construction Specification:

Wall lining; inner leaf blockwork; Eco-Cavity Full Fill board;
10mm residual cavity; brickwork

U-value Range Covered:

Inner Block Density	U-value achieved
0.15 W/mK	0.18 W/m ² K
0.51 W/mK	0.19 W/m ² K
1.13 W/mK	0.20 W/m ² K

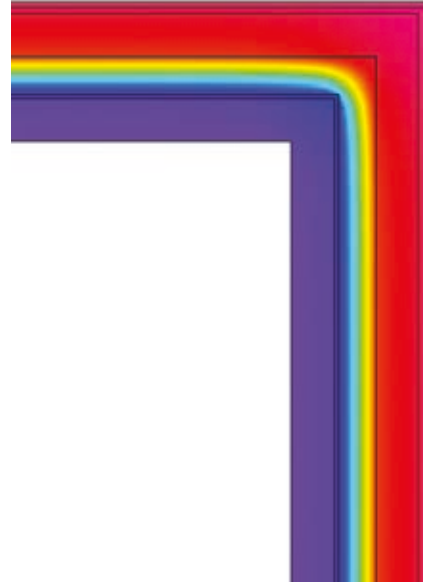
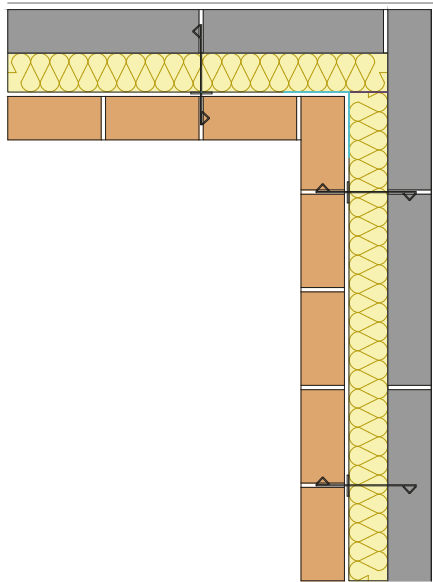

Thermal Performance Process Sequence:

- Ensure Eco-Cavity Full Fill board joints are staggered at the building corners
- Ensure the Eco-Cavity Full Fill board is firmly held against the inner leaf of blockwork
- Ensure cavity and wall ties are kept clean of mortar or other debris during construction
- T&G edges to be tightly interlocked
- T&G edges (tongue) to be trimmed at interfaces to form a tight butt edge
- Mitred corner joints are also acceptable, and will achieve the same thermal performance

Air Barrier Process Sequence:

- Seal the gap between the wall and ceiling linings with flexible sealant or plaster mortar
- Seal all penetrations through the air barrier using a flexible sealant

Results:

Description	Internal Blockwork Conductivity (W/mK)		
	0.15	0.51	1.13
Linear Thermal Transmittance ψ (W/mK)	-0.072	-0.080	-0.082
Temperature Factor (f)	0.978	0.974	0.968

E18 - Party Wall between Dwellings

(filled cavity)

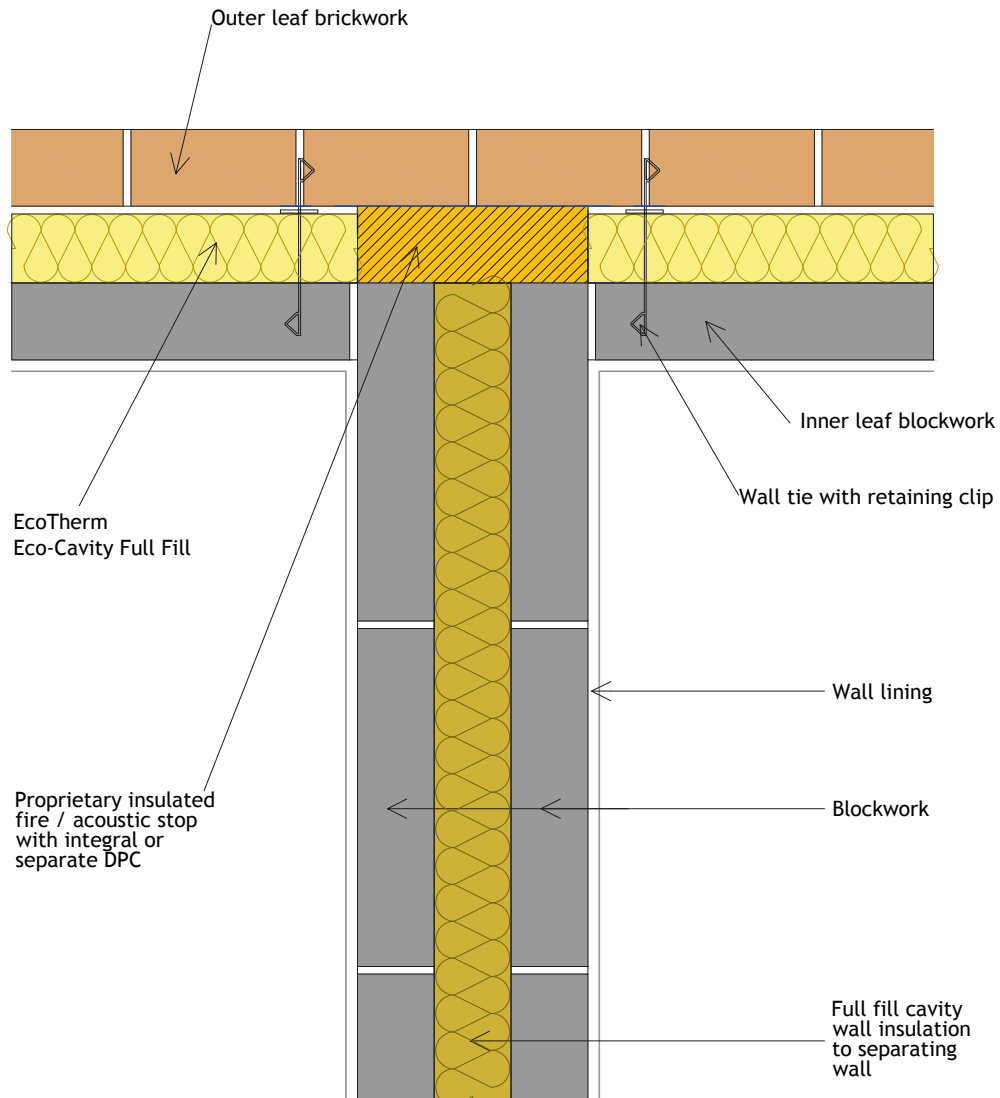

General Construction Specification:

Wall lining; inner leaf blockwork; Eco-Cavity Full Fill board; 10mm residual cavity; brickwork

U-value Range Covered:

Inner Block Density	U-value achieved
0.15 W/mK	0.18 W/m ² K
0.51 W/mK	0.19 W/m ² K
1.13 W/mK	0.20 W/m ² K

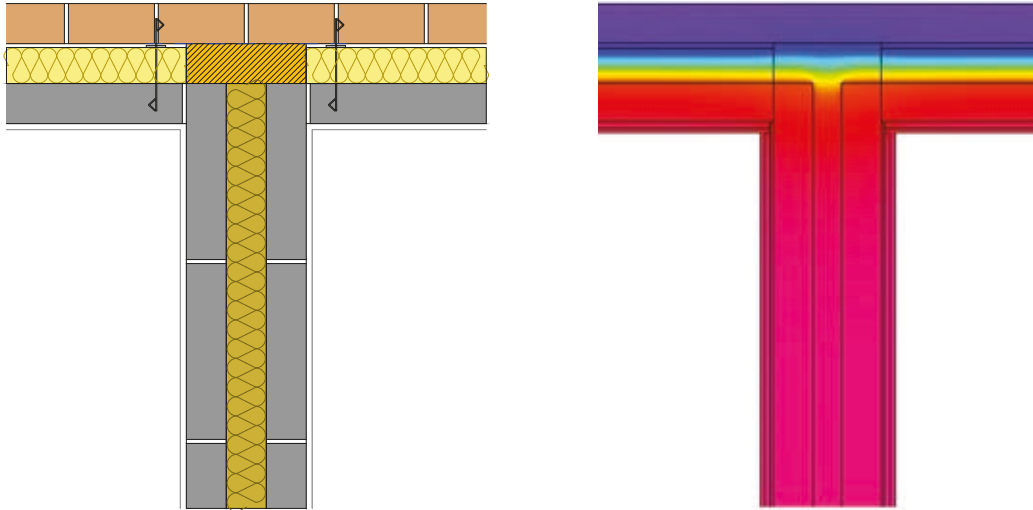

Thermal Performance Process Sequence:

- Ensure the Eco-Cavity Full Fill board insulation is firmly butted against the insulated fire stop
- Ensure all Eco-Cavity Full Fill board joints are lightly butted
- Ensure the Eco-Cavity Full Fill board is firmly held against the inner leaf of blockwork
- Ensure the Eco-Cavity Full Fill board and insulated fire stop material is continuous across the abutment zone
- Ensure cavity and wall ties are kept clean of mortar or other debris during construction
- T&G edges to be tightly interlocked
- T&G edges (tongue) to be trimmed at interfaces to form a tight butt edge

Air Barrier Process Sequence:

- Seal the gap between the wall and ceiling linings with flexible sealant or plaster mortar
- Seal all penetrations through the air barrier using a flexible sealant

Results:

Description	Internal Blockwork Conductivity (W/mK)		
	0.15	0.51	1.13
Linear Thermal Transmittance ψ (W/mK)	0.017	0.015	0.015
Temperature Factor (f)	0.940	0.942	0.945

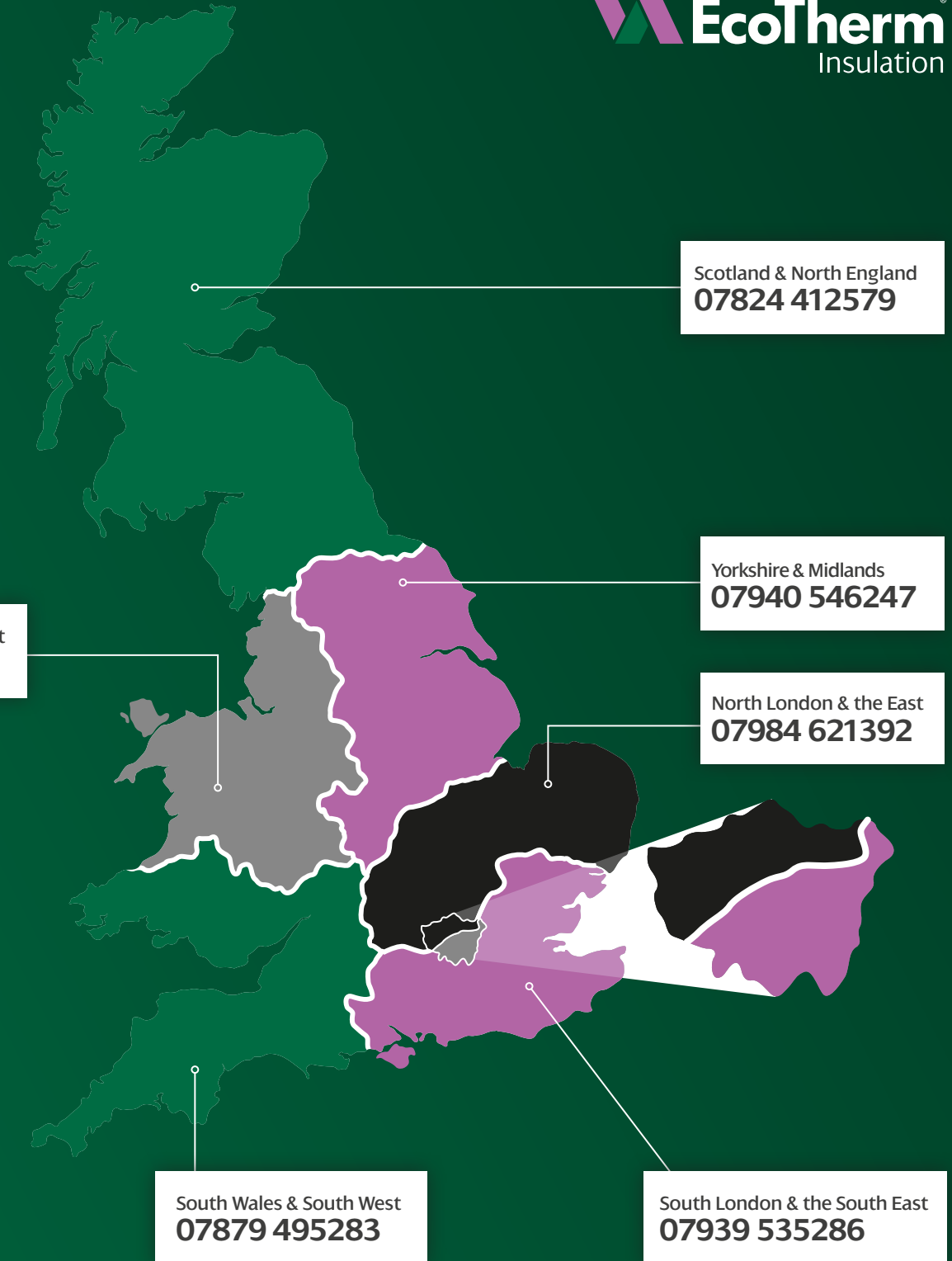

Any Questions?

EcoTherm Technical Services can help:

01268 597 212

technical@ecotherm.co.uk

EcoTherm Insulation (UK) Ltd

Harvey Road, Burnt Mills Ind. Est.

Basildon Essex SS13 1QJ

Main tel: +44 (0) 1268 597300

Technical Services: 01268 597 212

info@ecotherm.co.uk