

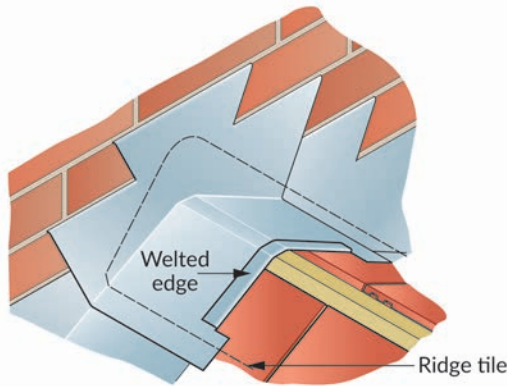

### Ridge saddles

#### A. Ridge saddle at abutment (bossed)



#### B. Ridge saddle at abutment (lead-welded)

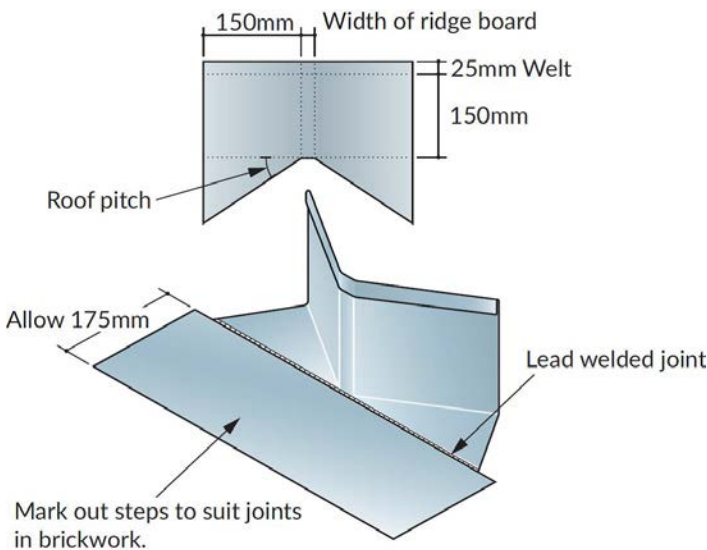

#### C. Ridge saddle at the top of a valley

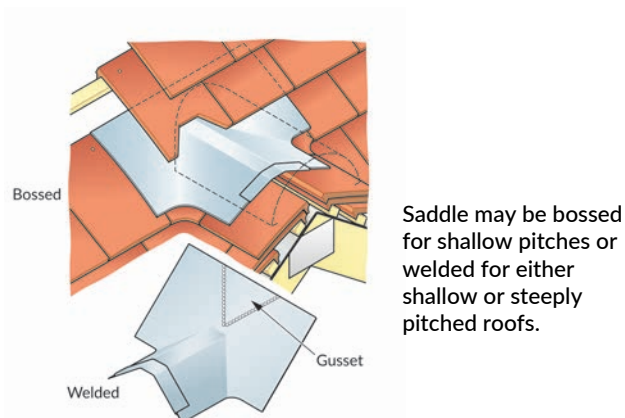

### Ridge and hip flashings

#### A. Cross section

No ridge flashing to exceed 1.5m in length for Code 4 and 2m in length for Codes 5, 6, 7, and 8.

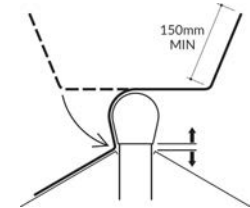

\* Roll fixed 5mm (MIN) above slate line

#### B. Ridge flashing

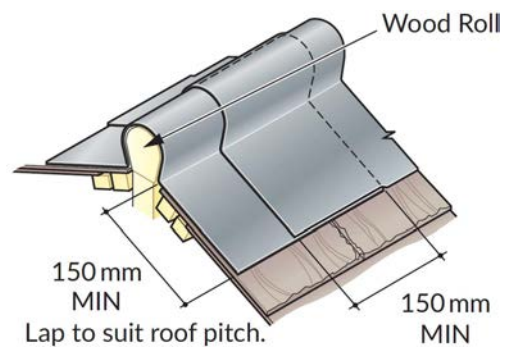

Free edges clipped to suit exposure using Copper Strip or Permastrip.

#### C. Ridge and hip intersection

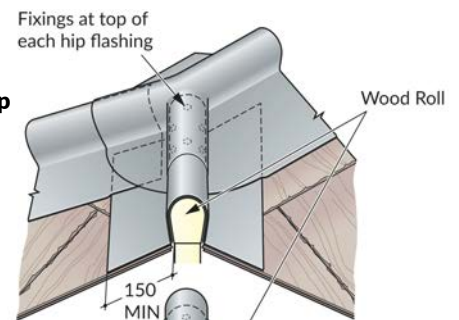

#### D. Hip flashing

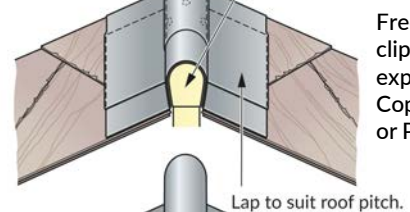

Free edges clipped to suit exposure using Copper Strip or Permastrip.

#### E. Hip flashing roll end

