

Fixing free edges of flashings

A. Clips for flashings over interlocking tiles

All flashings should be secured against the risk of wind lift. Position fixing clips at between 300-500mm centres depending upon the degree of exposure to wind.

Clips should be made from quarter hard copper, at least 0.6mm thick or stainless steel at least 0.38mm thick. Turn the clips over by at least 25mm. Allow for 6mm expansion of the lead in to the clip.

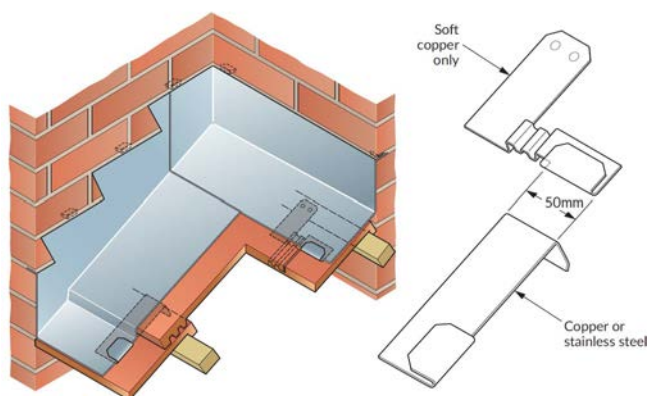

B. Clip to ridge or hip roll

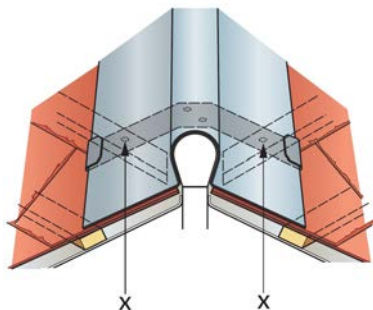

C. Clip to apron flashings

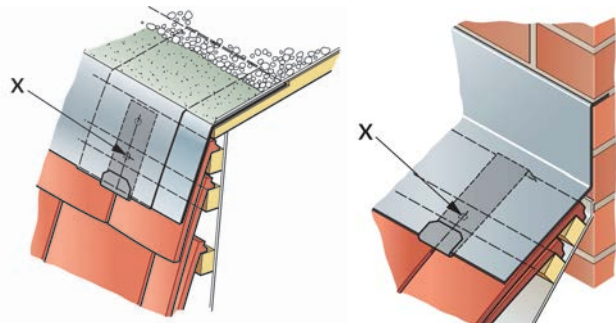

x = For moderate to severe exposures additional fixings should be positioned at not more than 75mm from the free edge. Secure clips with Copper Nails.

Step and cover flashings and secret gutters

A. Step and cover flashing to profiled tiles

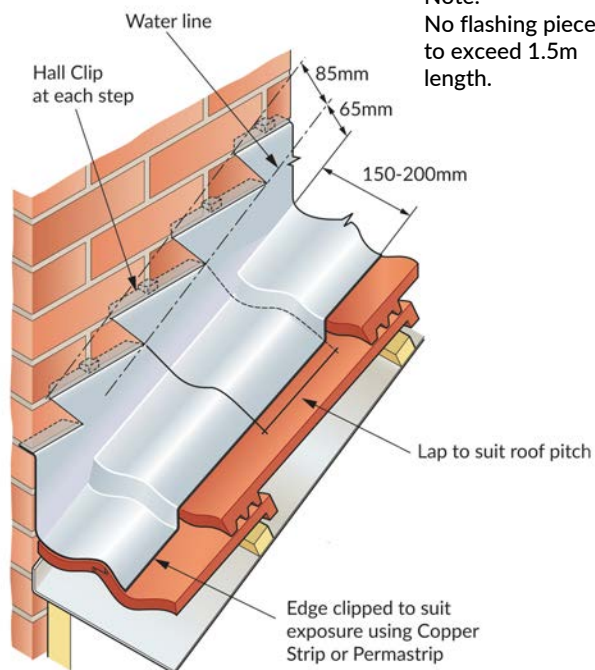

B. Abutment step and cover flashing with secret gutter

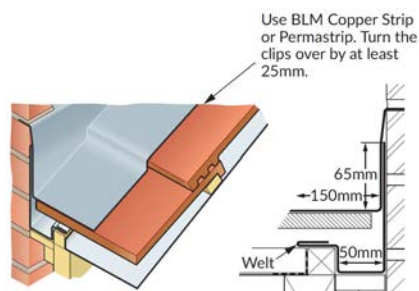

C. Abutment flashing with secret gutter

